

MATERIAL

HOUSING: NYLON66, UL94V-0
 CAGE: COPPER ALLOY, M3/Ni PLATED
 SCREW: STEEL, M3, TORQUE: 0.5N.m
 PIN: COPPER ALLOY, Sn PLATED

MECHANICAL

OPERATING TEMPERATURE: -40°C~+105°C
 SOLDERING TEMPERATURE: 260°C/5S
 STRIPPING LENGTH: 6~7mm

TECHNICAL DATA

UL/CUL

SAFETY APPROVAL			
USE GROUP	B	C	D
RATED VOLTAGE (V)	300	-	300
RATED CURRENT (A)	30	-	10
WIRE RANGE	26-10		
SOLID/STRANDED (AWG)			
WITHSTANDING VOLTAGE	1600V (1MIN)		

IEC			
OVERVOLTAGE CATEGORY	III	III	II
CONTAMINATION CLASS	3	2	2
RATED VOLTAGE (V)	500	630	1000
RATED CURRENT (A)	32	32	32
IMPULSE WITHSTANDING VOLTAGE (KV)	6.0	6.0	6.0
CONDUCTOR CROSS SECTION SOLID/FLEXIBLE (mm ²)	0.5-4.0		

ORDER INFORMATION

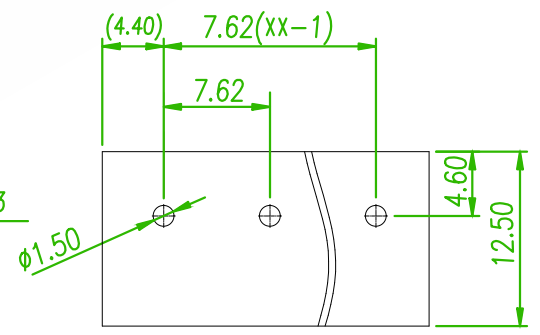
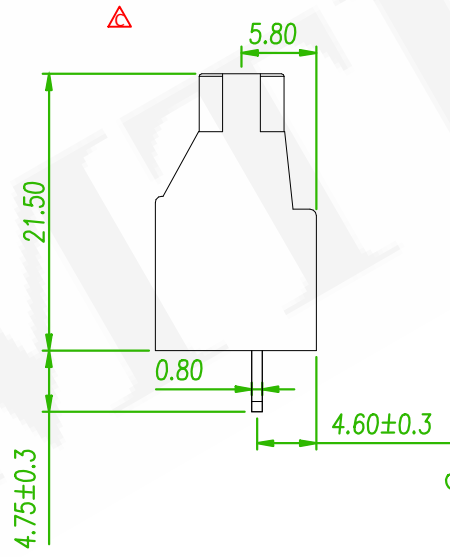
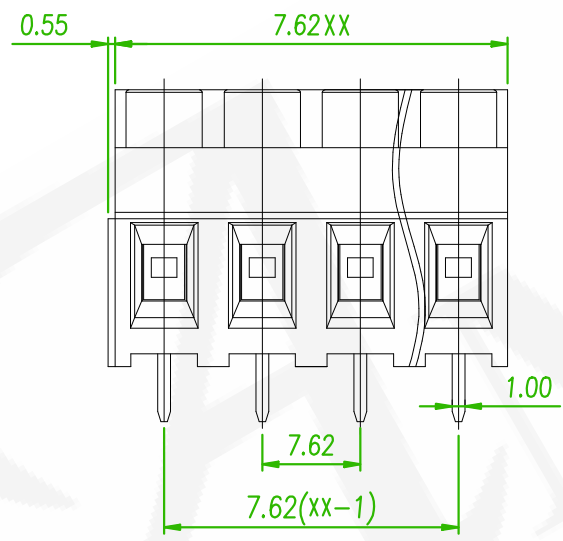
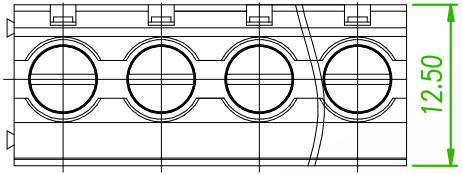
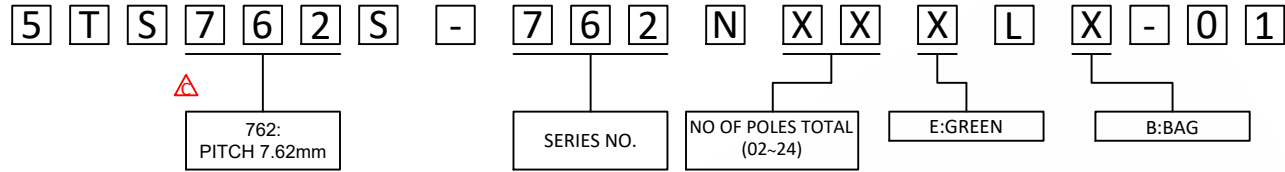

RECOMMENDED PCB LAOUT (PCB TOLERANCE ±0.05)

linear dimension (Tolerances Standard GB/T 14486-2008)								—		
variable range	to 6	over 6 to 10	over 10 to 30	over 30 to 60	over 60 to 100	over 100 to 160	over 160 to 10	over 10 to 100	over 100 to 100	
tolerance	±0.20	±0.30	±0.50	±0.70	±1.00	±1.30	±1.60	0.10	0.30	0.60

	ECN NO:240348 Revise the drawing	Gaby	2024/07/26
	ECN NO:200718 Revise the Tolerance	Alice	2020/12/10
REV.	ECN NO. OR DESCRIPTION	REVISED	DATE

糧德精密有限公司
 Amtek Technology Co., Ltd.
 TEL: 886-2-2260-6878
 FAX: 886-2-2260-8030

品名 TITLE	TERMINAL BLOCK PCB SCREW 7.62mm DIP V/T TYPE				頁數 Page	1/1
品號 PART NO.	5TS762S-762NXXXLX-01			繪圖 DRAWN	ROY	2016/02/16
圖號 DRAWING NO.	GN011-AL638	版本 REV.	C	核對 CHECKED	WANLING	2016/02/16
客戶品號 CUSTOMER P/N		比例 SCALE	None	承認 APPROVED	JOHN	2016/02/16
公差 TOLERANCE		單位 UNIT	mm	THIRD ANGLE PROJECTION		