

**MATERIAL**

HOUSING: NYLON66, UL94V-0  
 COVER: NYLON66, UL94V-0  
 SCREW: STEEL, M2.5/Zn PLATED, TORQUE: 0.4N.m  
 CLAMP BLOCK: STEEL, Zn PLATED  
 CAGE: STEEL, M2.5/Zn PLATED  
 HEADER PIN: COPPER ALLOY, Sn PLATED

**ORDER INFORMATION**

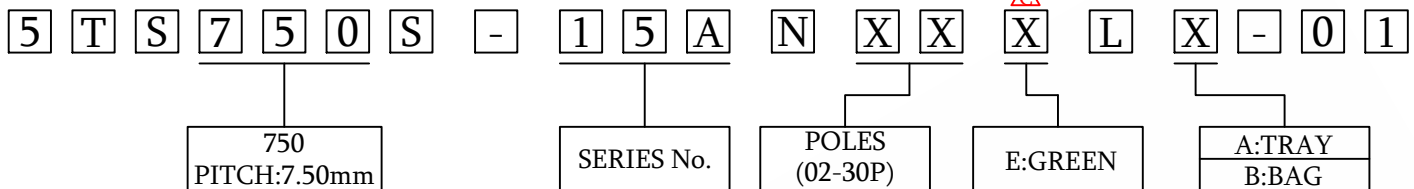

**MECHANICAL**

OPERATING TEMPERATURE: -40°C ~ +105°C  
 SOLDERING TEMPERATURE: 260°C/5S  
 STRIPPING LENGTH: 9mm

**TECHNICAL DATA**

UL/CUL

SAFETY APPROVAL			
USE GROUP	B	C	D
RATED VOLTAGE (V)	300	-	300
RATED CURRENT (A)	20	-	10
WIRE RANGE	26-12		
SOLID/STRANDED (AWG)			
WITHSTANDING VOLTAGE	1600V (1MIN)		

IEC IEC60947-7-4

OVERVOLTAGE CATEGORY	III	III	II
CONTAMINATION CLASS	3	2	2
RATED VOLTAGE (V)	450	630	1000
RATED CURRENT (A)	24	24	24
IMPULSE WITHSTANDING VOLTAGE (KV)	6.0	6.0	6.0
CONDUCTOR CROSS SECTION SOLID/FLEXIBLE (mm <sup>2</sup> )	0.5-2.5		

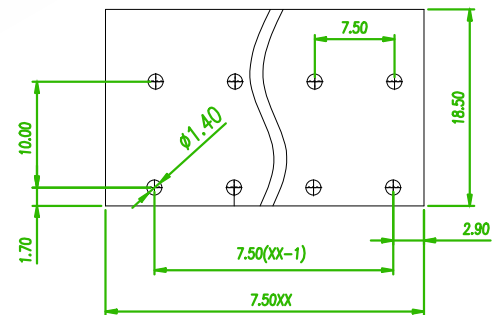
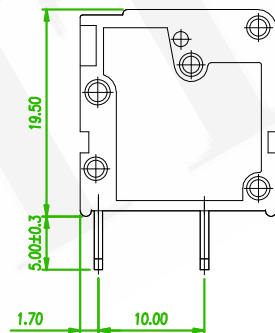
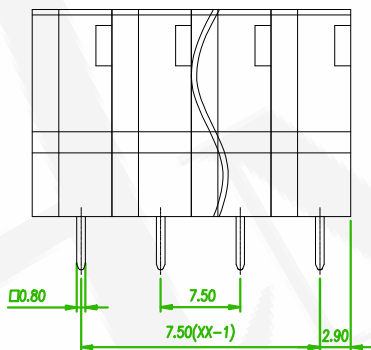
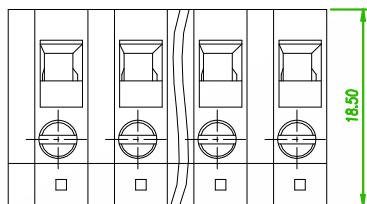

RECOMMENDED PCB LAOUT (PCB TOLERANCE ±0.05)



linear dimension (Tolerances Standard GB/T 14486-2008)								—		⊥
variable range	to 6	over 6 to 10	over 10 to 30	over 30 to 60	over 60 to 100	over 100 to 160	to 10	over 10 to 100	to 100	
tolerance	±0.20	±0.30	±0.50	±0.70	±1.00	±1.30	±1.60	0.10	0.30	0.60

	ECN NO:240348 Revise the drawing	Gaby	2025/02/11
	ECN NO:200718 Revise the Tolerance	Alice	2020/12/10
REV.	ECN NO. OR DESCRIPTION	REVISED	DATE

懋德精密有限公司  
 Amtek Technology Co., Ltd.  
 TEL: 886-2-2260-6878  
 FAX: 886-2-2260-8030

品名 TITLE	TERMINAL BLOCK PCB SCREW 7.50mm DIP V/T TYPE				頁數 Page	1/1
品號 PART NO.	5TS750S-15ANXXLX-01			繪圖 DRAWN	ERIC 2018/11/26	
圖號 DRAWING NO.	GN011-EA090	版本 REV.	C	核對 CHECKED	JOSH 2018/11/26	
客戶品號 CUSTOMER P/N		比例 SCALE	None	承認 APPROVED	JASON 2018/11/26	
公差 TOLERANCE		單位 UNIT	mm	THIRD ANGLE PROJECTION		