



ORDER INFORMATION

MATERIAL 
 HOUSING: NYLON66, UL94V-0
 CAGE: COPPER ALLOY, M2.5/Ni PLATED
 SCREW: STEEL, M2.5/Zn PLATED, TORQUE: 0.4N.m
 PIN: COPPER ALLOY, Sn PLATED

5 T S 7 5 0 R - 1 2 8 N X X X L X - 0 1

POLES (02-24P)
 E: GREEN
 A: TRAY
 B: BAG

MECHANICAL
 OPERATING TEMPERATURE: -40°C~+105°C
 SOLDERING TEMPERATURE: 260°C/5S
 STRIPPING LENGTH: 6~7mm

TECHNICAL DATA 
 UL/CUL

SAFETY APPROVAL			
USE GROUP	B	C	D
RATED VOLTAGE (V)	300	-	300
RATED CURRENT (A)	16	-	10
WIRE RANGE	22-12		
SOLID/STRANDED (AWG)			
WITHSTANDING VOLTAGE	1600V (1MIN)		

IEC

SAFETY APPROVAL			
OVERVOLTAGE CATEGORY	III	III	II
CONTAMINATION CLASS	3	2	2
RATED VOLTAGE (V)	450	630	1000
RATED CURRENT (A)	20	20	20
IMPULSE WITHSTANDING VOLTAGE (KV)	6.0	6.0	6.0
CONDUCTOR CROSS SECTION	0.5-2.5		
SOLID/FLEXIBLE (mm ²)			

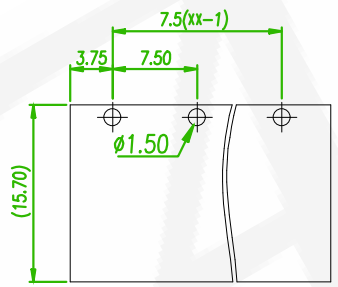

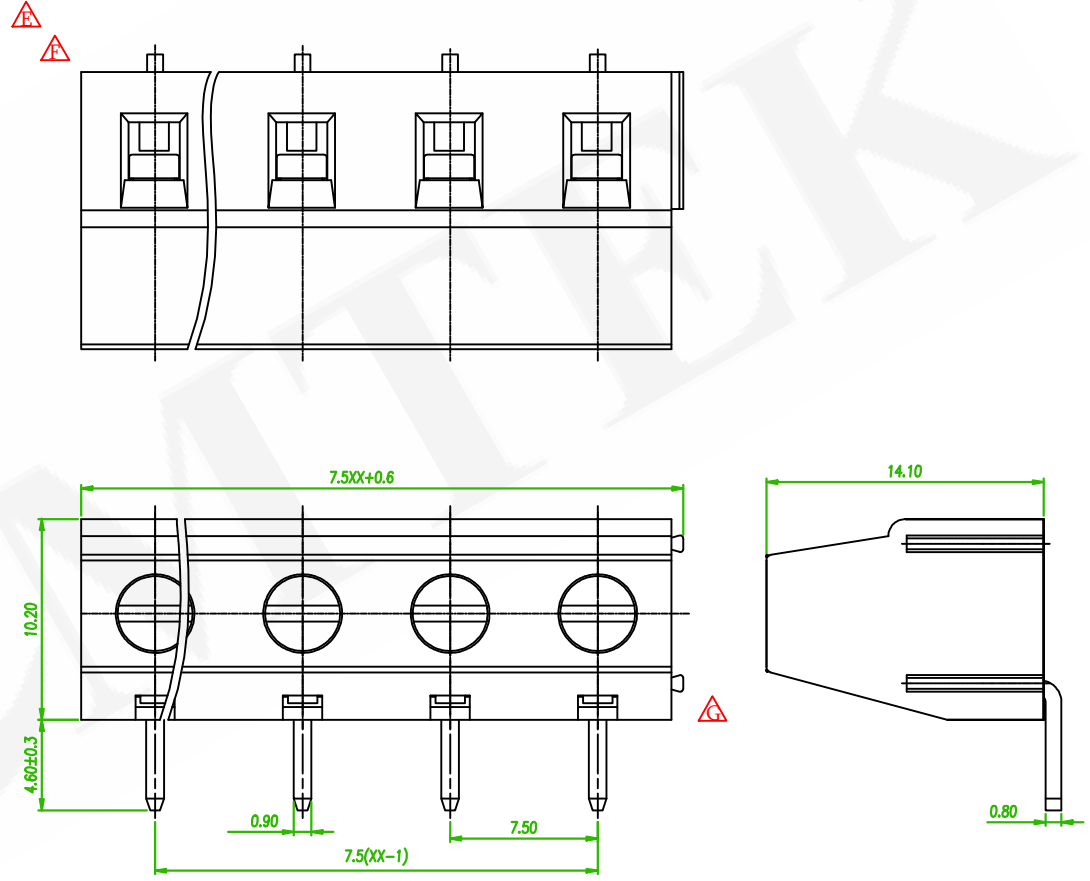

RECOMMENDED PCB LAYOUT
 (PCB TOLERANCE ±0.05)



 linear dimension (Tolerances Standard GB/T 14486-2008)

		over 6	over 10	over 30	over 60	over 100	over 160		over 10	over 100
variable range	to 6	to 10	to 30	to 60	to 100	to 160	to 10	to 100	to 100	to 100
tolerance	±0.20	±0.30	±0.50	±0.70	±1.00	±1.30	±1.60	0.10	0.30	0.60

	ECN-202512027 Revise the drawing	GABY	2025/12/24
	ECN NO:240348 Revise the drawing	John	2025/01/23
	ECN NO:240348 Revise the drawing	GABY	2024/07/18
REV.	ECN NO. OR DESCRIPTION	REVISED	DATE



懋德精密有限公司
 Amtek Technology Co., Ltd.
 TEL: 886-2-2260-6878
 FAX: 886-2-2260-8030

品名 TITLE	TERMINAL BLOCK PCB SCREW 7.50mm DIP R/A TYPE				頁數 Page	1/1
品號 PART NO.	5TS750R-128NXXXLX-01			繪圖 DRAWN	ERIC 2018/11/21	
圖號 DRAWING NO.	GN011-EA048	版本 REV.	G	核對 CHECKED	JOSH 2018/11/21	
客戶品號 CUSTOMER P/N		比例 SCALE	None	承認 APPROVED	JOSH 2018/11/21	
公差 TOLERANCE		單位 UNIT	mm	THIRD ANGLE PROJECTION	