

MATERIAL ⚠

HOUSING: NYLON66, UL94V-0
CAGE: COPPER ALLOY, M3/Ni PLATED
SCREW: STEEL, M3/Zn PLATED, TORQUE: 0.5N.m
PIN: COPPER ALLOY, Sn PLATED

ORDER INFORMATION

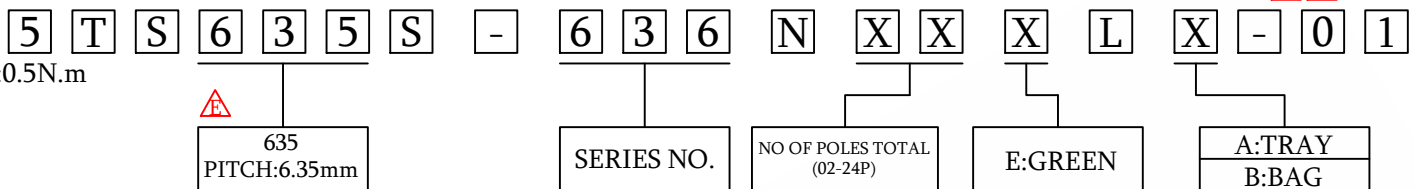

MECHANICAL

OPERATING TEMPERATURE: -40°C~+105°C
SOLDERING TEMPERATURE: 260°C/5S
STRIPPING LENGTH: 7~8mm

TECHNICAL DATA ⚠

SAFETY APPROVAL			
USE GROUP	B	C	D
RATED VOLTAGE (V)	300	-	300
RATED CURRENT (A)	30	-	10
WIRE RANGE SOLID/STRANDED (AWG)	26-10		
WITHSTANDING VOLTAGE	1600V (1MIN)		

SAFETY APPROVAL			
OVERVOLTAGE CATEGORY	III	III	II
CONTAMINATION CLASS	3	2	2
RATED VOLTAGE (V)	400	630	1000
RATED CURRENT (A)	32	32	32
IMPULSE WITHSTANDING VOLTAGE (KV)	6.0	6.0	6.0
CONDUCTOR CROSS SECTION SOLID/FLEXIBLE (mm ²)	0.5-4.0		

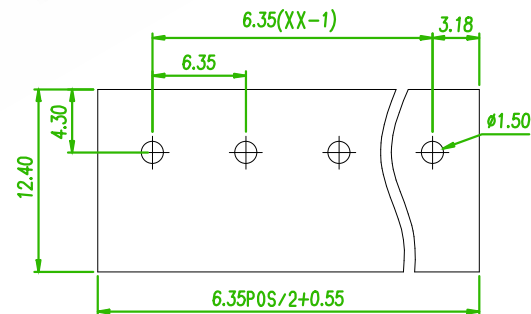
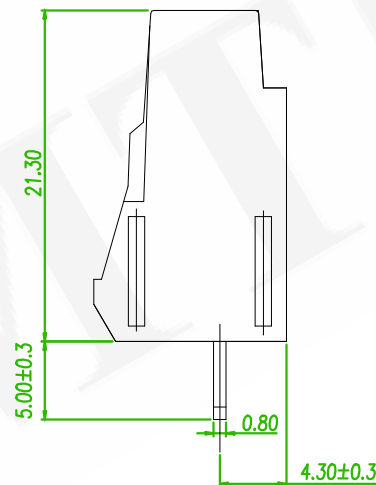
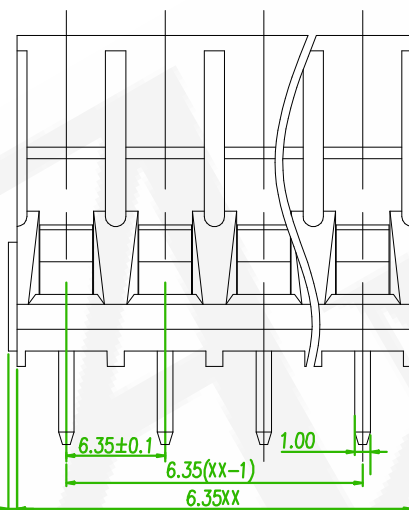
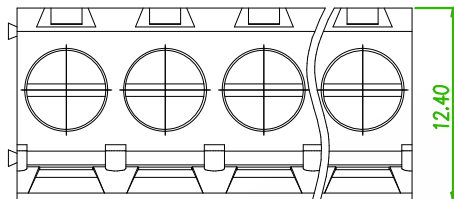

RECOMMENDED PCB LAOUT
(PCB TOLERANCE ±0.05)



linear dimension (Tolerances Standard GB/T 14486-2008)

		over	over	over	over	over	over		over	over
variable		6	10	30	60	100	160		10	100
range	to	to	to	to	to	to	to	to	to	to
	6	10	30	60	100	160	10	100		
tolerance	±0.20	±0.30	±0.50	±0.70	±1.00	±1.30	±1.60	0.10	0.30	0.60

⚠	ECN NO:240348 Revise the drawing	Gaby	2024/07/26
⚠	ECN NO:230714 Revise the PART NO.	Randy	2023/09/23
⚠x2	ECN NO:201214 Revise the PART NO.	Alice	2020/12/29
REV.	ECN NO. OR DESCRIPTION	REVISED	DATE

懋德精密有限公司
Amtek Technology Co., Ltd.
TEL: 886-2-2260-6878
FAX: 886-2-2260-8030

品名 TITLE	TERMINAL BLOCK PCB SCREW 6.35mm DIP V/T TYPE				頁數 Page	1/1
品號 PART NO.	5TS635S-636NXXXLX-01			繪圖 DRAWN	ERIC 2018/12/13	
圖號 DRAWING NO.	GN011-EA275	版本 REV.	E	核對 CHECKED	JOSH 2018/12/13	
客戶品號 CUSTOMER P/N		比例 SCALE	None	承認 APPROVED	JASON 2018/12/13	
公差 TOLERANCE		單位 UNIT	mm	第三 ANGLE PROJECTION		