

ORDER INFORMATION

5 T S 5 0 8 S - 1 2 5 N X X X L X - 0 1

508:
PITCH 5.08mm

SERIES NO. NO OF POLES TOTAL (02~24) E:GREEN B:BAG

Mechanical

TEMP. RANGE: -40°C ~ +105°C
STRIPPING LENGTH: 6-7mm
SOLDERING TEMPERATURE: 260°C/5S

Material

HOUSING: PA66, UL94V-0
COVER: PA66, UL94V-0
CONTACT PIN: COPPER ALLOY, Sn PLATED
CAGE: COPPER ALLOY, Ni PLATED
SCREWS: STEEL M2.5, Zn PLATED, TORQUE, 0.4Nm

TECHNICAL DATA

UL/CUL

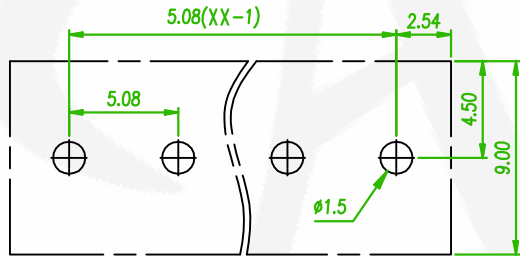
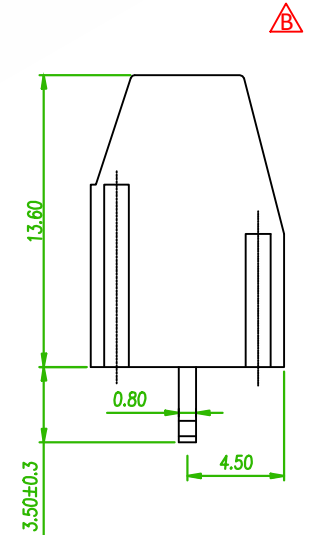
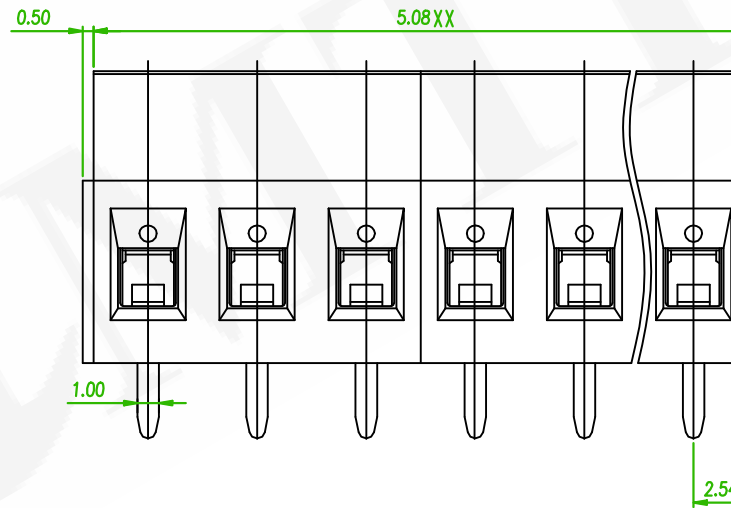
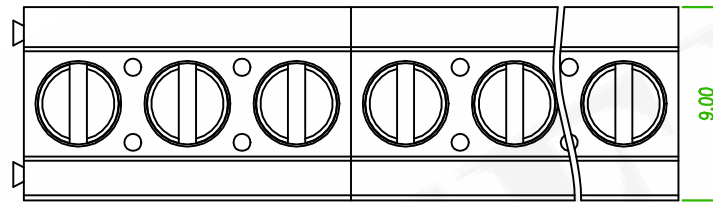

SAFETY APPROVAL			
USE GROUP	B	C	D
RATED VOLTAGE (V)	300	-	300
RATED CURRENT (A)	16	-	10
WIRE RANGE	22-12		
SOLID/STRANDED (AWG)			
WITHSTANDING VOLTAGE	1600V (1MIN)		

IEC IEC60947-7-4			
OVERVOLTAGE CATEGORY	III	III	II
CONTAMINATION CLASS	3	2	2
RATED VOLTAGE (V)	250	400	630
RATED CURRENT (A)	18	18	18
IMPULSE WITHSTANDING VOLTAGE (KV)	4.0	4.0	4.0
CONDUCTOR CROSS SECTION	0.2-2.5		
SOLID/FLEXIBLE (mm ²)			



RECOMMENDED PCB LAYOUT
(PCB TOLERANCE ±0.05)

linear dimension (Tolerances Standard GB/T 14486-2008)										
variable range	to 6	over 6 to 10	over 10 to 30	over 30 to 60	over 60 to 100	over 100 to 160	to 10	over 10 to 100	over 100 to 100	
tolerance	±0.20	±0.30	±0.50	±0.70	±1.00	±1.30	±1.60	0.10	0.30	0.60

 懋德精密有限公司 Amtek Technology Co., Ltd. TEL: 886-2-2260-6878 FAX: 886-2-2260-8030	品名 TITLE	TERMINAL BLOCK PCB SCREW 5.08mm DIP V/T TYPE				頁數 Page	1/1
	品號 PART NO.	5TS508S-125NXXXLX-01				繪圖 DRAWN	DAVID 2020/02/24
	圖號 DRAWING NO.	GN011-DV834	版本 REV.	C	核對 CHECKED	JOSH 2020/02/24	
	客戶品號 CUSTOMER P/N		比例 SCALE	None	承認 APPROVED	JOSH 2020/02/24	
	公差 TOLERANCE		單位 UNIT	mm	THIRD ANGLE PROJECTION		

	ECN NO.: 240348 Revise the drawing	Gaby	2024/05/02
REV.	ECN NO. OR DESCRIPTION	REVISED	DATE