

MATERIAL

HOUSING: NYLON66, UL94V-0
PIN: COPPER ALLOY, Sn PLATED
CAGE: COPPER ALLOY, M2.5/Ni PLATED
SCREW/TORQUE: M2.5/0.4N.m

ORDER INFORMATION

5 T S 5 0 8 R - 1 2 8 N X X X L X - 0 1

508
PITCH: 5.08mm



SERIES NO.

POLES
(02-24P)

E: GREEN

A: TRAY
B: BAG

MECHANICAL

OPERATING TEMPERATURE: -40°C~+105°C
SOLDERING TEMPERATURE: 260°C/5S
STRIPPING LENGTH: 6~7mm

TECHNICAL DATA

UL/CUL



SAFETY APPROVAL			
USE GROUP	B	C	D
RATED VOLTAGE (V)	300	-	300
RATED CURRENT (A)	16	-	10
WIRE RANGE	22-12		
SOLID/STRANDED (AWG)			
WITHSTANDING VOLTAGE	1600V (1MIN)		

IEC	IEC 60947-7-4		
OVERVOLTAGE CATEGORY	III	III	II
CONTAMINATION CLASS	3	2	2
RATED VOLTAGE (V)	250	400	630
RATED CURRENT (A)	20	20	20
IMPULSE WITHSTANDING VOLTAGE (KV)	4.0	4.0	4.0
CONDUCTOR CROSS SECTION	0.5-2.5		
SOLID/FLEXIBLE (mm ²)			

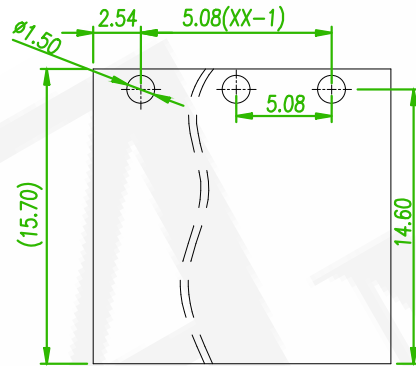

RECOMMENDED PCB LAYOUT
(PCB TOLERANCE ±0.05)

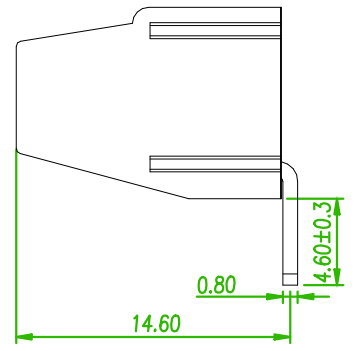
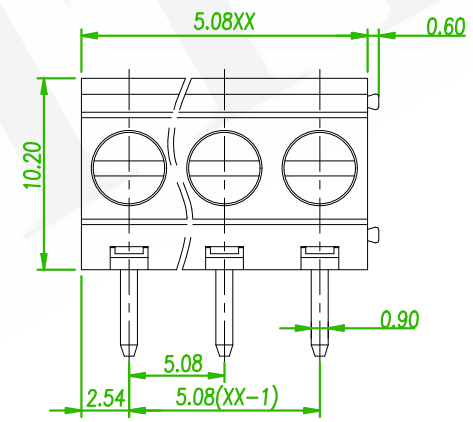
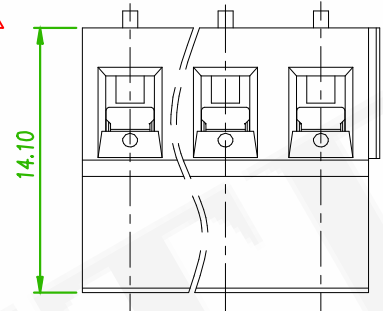

linear dimension (Tolerances Standard GB/T 14486-2008)								—		
variable range	to 6	over 6 to 10	over 10 to 30	over 30 to 60	over 60 to 100	over 100 to 160	over 160 to 10	over 10 to 100	over 100 to 100	
tolerance	±0.20	±0.30	±0.50	±0.70	±1.00	±1.30	±1.60	0.10	0.30	0.60

	ECN NO: 240348 Revise the drawing	Gaby	2024/07/18
	ECN NO: 200718 Revise the Tolerance	Alice	2020/12/08
REV.	ECN NO. OR DESCRIPTION	REVISED	DATE

懋德精密有限公司
Amtek Technology Co., Ltd.
TEL: 886-2-2260-6878
FAX: 886-2-2260-8030

品名 TITLE	TERMINAL BLOCK PCB SCREW 5.08mm DIP R/A TYPE				頁數 Page	1/1
品號 PART NO.	5TS508R-128NXXXLX-01			繪圖 DRAWN	ERIC	
圖號 DRAWING NO.	GN011-EA274	版本 REV.	C	核對 CHECKED	JOSH	
客戶品號 CUSTOMER P/N		比例 SCALE	None	承認 APPROVED	JASON	
公差 TOLERANCE		單位 UNIT	mm	第三角 ANGLE PROJECTION		