

MECHANICAL

TEMP. RANGE: -40°C ~ +105°C
STRIP LENGTH: 5-6mm
SOLDERING TEMPERATURE: 260°C/5S

ORDER INFORMATION

5 T S 5 0 8 R - 1 2 7 N X X X L X - 0 1

MATERIAL

HOUSING: PA66, UL94V-0
SCREWS: M2.5 STEEL, Zn PLATED, TORQUE: 0.4N.m
PIN: COPPER ALLOY, Sn PLATED
CAGE: COPPER ALLOY, Ni PLATED

508
PITCH: 5.08mm

SERIES NO.

POLES
(02-24P)

E: GREEN

A: TRAY
B: BAG

TECHNICAL DATA

UL/CUL

SAFETY APPROVAL			
USE GROUP	B	C	D
RATED VOLTAGE (V)	300	-	300
RATED CURRENT (A)	12	-	10
WIRE RANGE	26-14		
SOLID/STRANDED (AWG)			
WITHSTANDING VOLTAGE	1600V (1MIN)		

IEC	IEC 6047-4		
OVERVOLTAGE CATEGORY	III	III	II
CONTAMINATION CLASS	3	2	2
RATED VOLTAGE (V)	250	400	630
RATED CURRENT (A)	17.5	17.5	17.5
IMPULSE WITHSTANDING VOLTAGE (KV)	4.0	4.0	4.0
CONDUCTOR CROSS SECTION			
SOLID/FLEXIBLE (mm ²)	0.5-1.5		

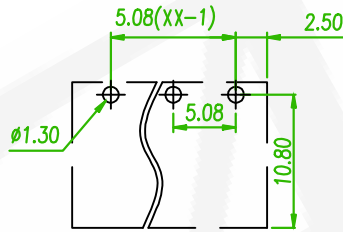

RECOMMENDED PCB LAYOUT
(PCB TOLERANCE ±0.05)

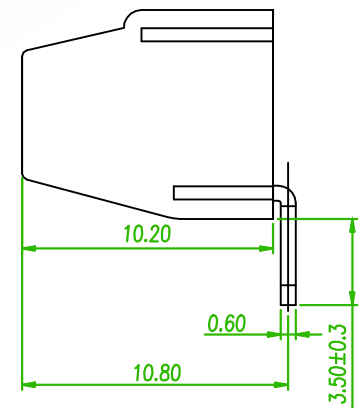
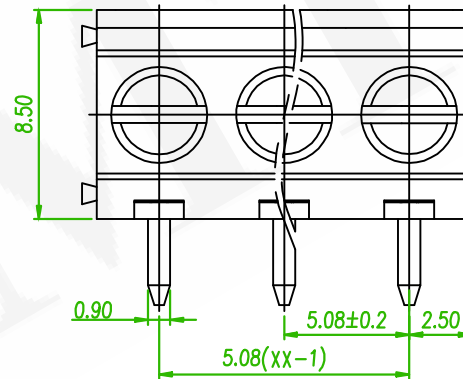
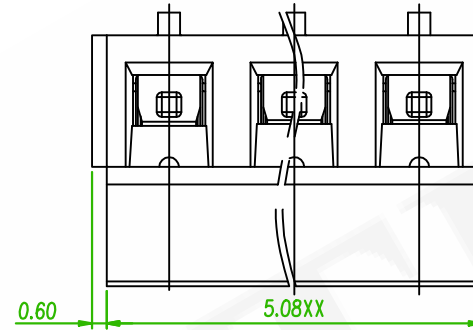

linear dimension (Tolerances Standard GB/T 14486-2008)							—	∥	⊥	
variable range	to 6	over 6 to 10	over 10 to 30	over 30 to 60	over 60 to 100	over 100 to 160	to 10	over 10 to 100	over 100 to	
tolerance	±0.20	±0.30	±0.50	±0.70	±1.00	±1.30	±1.60	0.10	0.30	0.60

△	ECN NO.: 240348 Revise the drawing	Gaby	2024/05/03
△	ECN NO.: 2307014 Revise the PART NO.	Randy	2023/09/23
△x2	ECN NO.: 201214 Revise the PART NO.	Alice	2020/12/29
REV.	ECN NO. OR DESCRIPTION	REVISED	DATE

糧德精密有限公司
Amtek Technology Co., Ltd.
TEL: 886-2-2260-6878
FAX: 886-2-2260-8030

品名 TITLE	TERMINAL BLOCK PCB SCREW 5.08mm DIP R/A TYPE				頁數 Page	1/1
品號 PART NO.	5TS508R-127NXXXLX-01			繪圖 DRAWN	ERIC 2018/11/20	
圖號 DRAWING NO.	GN011-EA034	版本 REV.	F	核對 CHECKED	JOSH 2018/11/20	
客戶品號 CUSTOMER P/N		比例 SCALE	None	承認 APPROVED	JASON 2018/11/20	
公差 TOLERANCE		單位 UNIT	mm	第三 ANGLE PROJECTION		