

MATERIAL

HOUSING: NYLON66, UL94V-0
 PIN: COPPER ALLOY, Sn PLATED
 SCREW: M2.5, TORQUE: 0.4N.m

ORDER INFORMATION

5 T S 5 0 0 S - K 5 A N X X X L X - 0 1

500
PITCH: 5.00mm

SERIES No.

No OF POLES TOTAL
(04~48P)

E: GREEN

L: RoHS + NYLON 66

B: BAG (2x2~2x3P)
X: BOX (2x4~2x24P)



MECHANICAL

OPERATING TEMPERATURE: -40°C~+105°C
 SOLDERING TEMPERATURE: 260°C/5S
 STRIPPING LENGTH: 6~7mm

TECHNICAL DATA

UL/CUL

| | | | |
|----------------------|--------------|---|-----|
| SAFETY APPROVAL | | | |
| USE GROUP | B | C | D |
| RATED VOLTAGE (V) | 300 | - | 300 |
| RATED CURRENT (A) | 15 | - | 10 |
| WIRE RANGE | 30-14 | | |
| SOLID/STRANDED (AWG) | | | |
| WITHSTANDING VOLTAGE | 1600V (1MIN) | | |

IEC

| | | | |
|-----------------------------------|---------|-----|-----|
| SAFETY APPROVAL | | | |
| OVERVOLTAGE CATEGORY | III | III | II |
| CONTAMINATION CLASS | 3 | 2 | 2 |
| RATED VOLTAGE (V) | 250 | 400 | 630 |
| RATED CURRENT (A) | 24 | 24 | 24 |
| IMPULSE WITHSTANDING VOLTAGE (KV) | 4.0 | 4.0 | 4.0 |
| CONDUCTOR CROSS SECTION | 0.5-2.5 | | |
| SOLID/FLEXIBLE (mm ²) | | | |

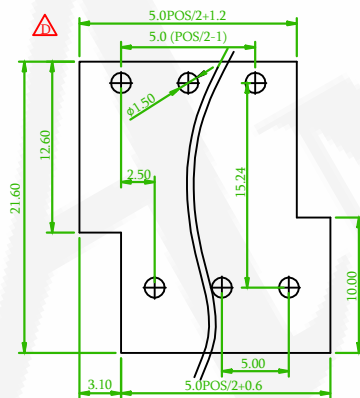
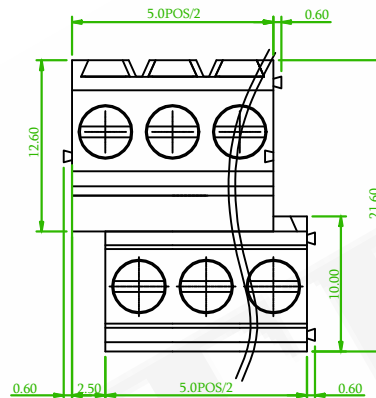

RRCOMMENDED P.C.B LAYOUT
(PCB TOLERANCE±0.1)

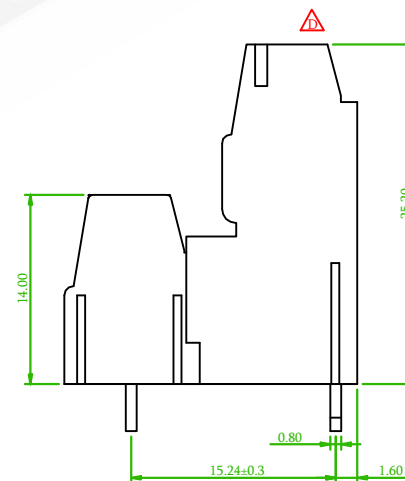
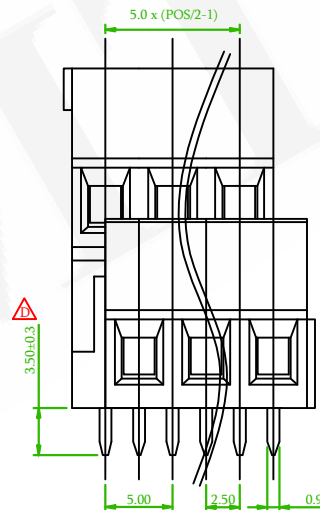

| | | | | | | | | | | |
|--|-------|--------------|---------------|---------------|----------------|-----------------|----------------|----------------|-----------------|------|
| linear dimension (Tolerances Standard GB/T 14486-2008) | | | | | | | | | | |
| variable range | to 6 | over 6 to 10 | over 10 to 30 | over 30 to 60 | over 60 to 100 | over 100 to 160 | over 160 to 10 | over 10 to 100 | over 100 to 100 | |
| tolerance | ±0.20 | ±0.30 | ±0.50 | ±0.70 | ±1.00 | ±1.30 | ±1.60 | 0.10 | 0.30 | 0.60 |

| | | | |
|------|-----------------------------------|---------|------------|
| | ECN NO:240348 Revise the drawing | Gaby | 2025/01/24 |
| | ECN NO:220814 Revise the PART NO. | Tim | 2022/09/16 |
| | QEC 220410.: Revise the drawing | Alice | 2022/05/10 |
| REV. | ECN NO. OR DESCRIPTION | REVISED | DATE |

| | | | | | | | |
|--|----------------------|--|-------------|------|------------------------|---------------------|-------------------|
| 糧德精密有限公司 Amtek Technology Co., Ltd. TEL: 886-2-2260-6878 FAX: 886-2-2260-8030 | 品名 TITLE | TERMINAL BLOCK SCREW PCB 5.00mm DIP V/T TYPE | | | | 頁數 Page | 1/1 |
| | 品號 PART NO. | 5TS500S-K5ANXXXLX-01 | | | | 繪圖 DRAWN | JOE 2010/08/26 |
| | 圖號 DRAWING NO. | GN011-MC705 | 版本 REV. | F | 核對 CHECKED | ALVIN 2024/05/07 | |
| | 客戶品號 CUSTOMER P/N | | 比例 SCALE | None | 承認 APPROVED | JAMES 2010/08/26 | |
| | 公差 TOLERANCE | | 單位 UNIT | mm | THIRD ANGLE PROJECTION | | |