

MATERIAL 
 HOUSING: NYLON66, UL94V-0
 CAGE: COPPER ALLOY, M2.5/Ni PLATED
 SCREW: STEEL, M2.5/Zn PLATED, TORQUE: 0.4N.m
 PIN: COPPER ALLOY, Sn PLATED

ORDER INFORMATION

5 T S 5 0 0 S - K 5 0 N X X X L X - 0 1

500:
PITCH 5.00mm

SERIES No.

NO OF POLES TOTAL
(02~24P)

B: BLACK
O: ORANGE
E: GREEN
U: BLUE
G: GRAY
R: RED

B: BAG

MECHANICAL
 OPERATING TEMPERATURE: -40°C~+105°C
 SOLDERING TEMPERATURE: 260°C/5S
 STRIPPING LENGTH: 6~7mm

TECHNICAL DATA 
 UL/CUL

SAFETY APPROVAL			
USE GROUP	B	C	D
RATED VOLTAGE (V)	300	-	300
RATED CURRENT (A)	15	-	10
WIRE RANGE	30-14		
SOLID/STRANDED (AWG)			
WITHSTANDING VOLTAGE	1600V (1MIN)		

IEC

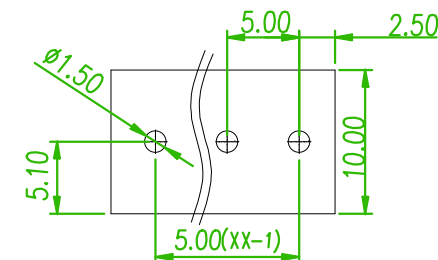
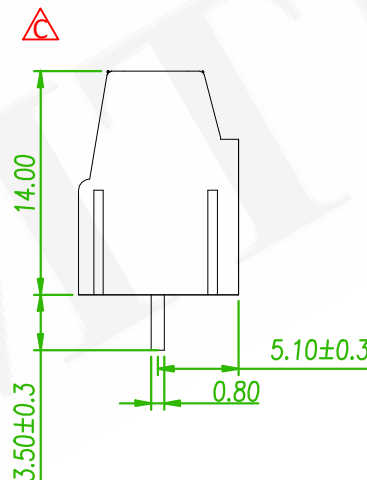
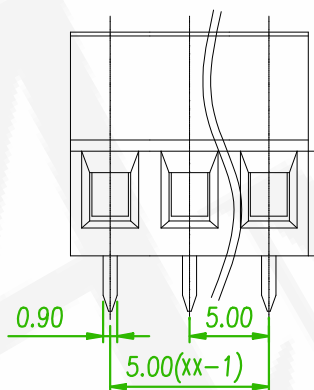
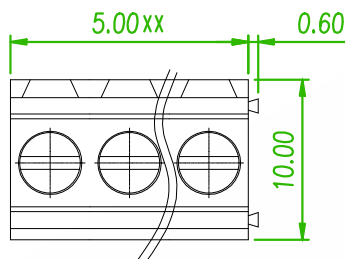

SAFETY APPROVAL			
OVERVOLTAGE CATEGORY	III	III	II
CONTAMINATION CLASS	3	2	2
RATED VOLTAGE (V)	250	400	630
RATED CURRENT (A)	24	24	24
IMPULSE WITHSTANDING VOLTAGE (KV)	4.0	4.0	4.0
CONDUCTOR CROSS SECTION SOLID/FLEXIBLE (mm ²)	0.5-2.5		



RECOMMENDED PCB LAOUT
(PCB TOLERANCE ±0.05)

linear dimension (Tolerances Standard GB/T 14486-2008)

variable range	to 6	over 6 to 10	over 10 to 30	over 30 to 60	over 60 to 100	over 100 to 160	to 10	over 10 to 100	to 100	
tolerance	±0.20	±0.30	±0.50	±0.70	±1.00	±1.30	±1.60	0.10	0.30	0.60

	ECN NO:240348 Revise the drawing	Gaby	2024/08/06
	QEC 190913: Revise the dimension · List · SPEC · Drawing	Nick	2019/10/14
REV.	ECN NO. OR DESCRIPTION	REVISED	DATE



糧德精密有限公司
Amtek Technology Co., Ltd.
TEL: 886-2-2260-6878
FAX: 886-2-2260-8030

品名 TITLE	TERMINAL BLOCK PCB SCREW 5.00mm DIP V/T TYPE				頁數 Page	1/1
品號 PART NO.	5TS500S-K50NXXXLX-01			繪圖 DRAWN	MIA 2016/10/24	
圖號 DRAWING NO.	GN011-N1433	版本 REV.	C	核對 CHECKED	JONNY 2016/10/24	
客戶品號 CUSTOMER P/N		比例 SCALE	None	承認 APPROVED	AARON 2016/10/24	
公差 TOLERANCE		單位 UNIT	mm	THIRD ANGLE PROJECTION	