

MATERIAL ⚠️

HOUSING: NYLON66, UL94V-0
CAGE: COPPER ALLOY, M3/Ni PLATED
SCREW: STEEL, M3, TORQUE: 0.5N.m
PIN: COPPER ALLOY, Sn PLATED

ORDER INFORMATION

5 T S 5 0 0 S - 3 2 A N X X X L X - 0 1

500
PITCH: 5.00mm

SERIES NO.

NO OF POLES TOTAL
(04~48P)

E: GREEN

A: TRAY
B: BAG

MECHANICAL

OPERATING TEMPERATURE: -40°C~+105°C
SOLDERING TEMPERATURE: 260°C/5S
STRIPPING LENGTH: 6~7mm

TECHNICAL DATA ⚠️

UL/CUL

SAFETY APPROVAL			
USE GROUP	B	C	D
RATED VOLTAGE (V)	300	-	300
RATED CURRENT (A)	20	-	10
WIRE RANGE SOLID/STRANDED (AWG)	26-12		
WITHSTANDING VOLTAGE	1600V (1MIN)		

IEC	IEC60917-74		
OVERVOLTAGE CATEGORY	III	III	II
CONTAMINATION CLASS	3	2	2
RATED VOLTAGE (V)	250	400	630
RATED CURRENT (A)	20	20	20
IMPULSE WITHSTANDING VOLTAGE (KV)	4.0	4.0	4.0
CONDUCTOR CROSS SECTION SOLID/FLEXIBLE (mm ²)	0.5-2.5		

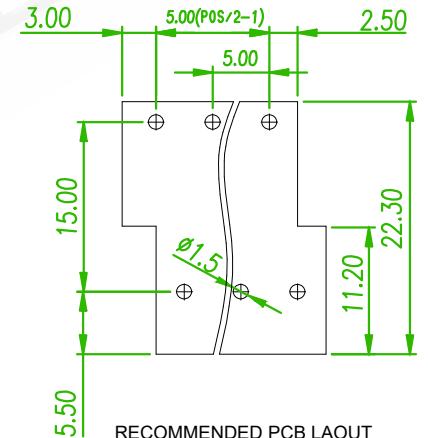
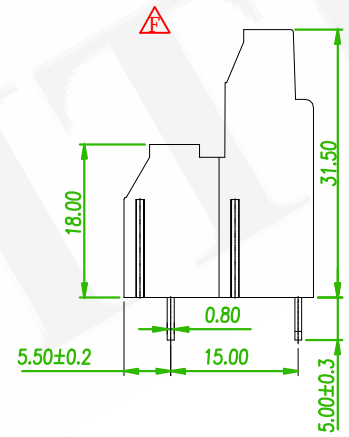
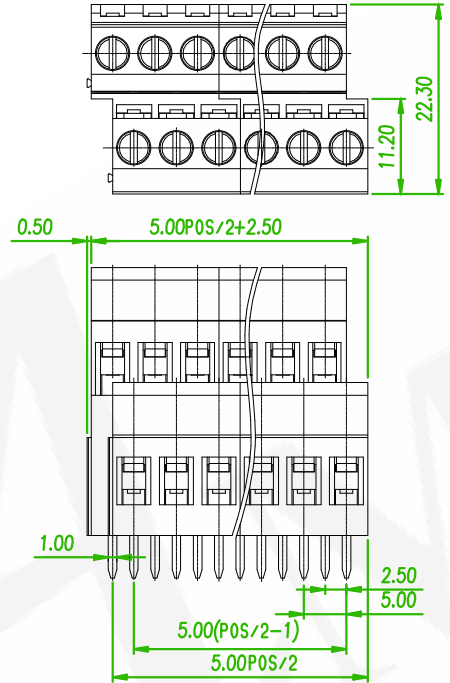

RECOMMENDED PCB LAOUT
(PCB TOLERANCE ±0.05)

linear dimension (Tolerances Standard GB/T 14486-2008)								—	∥	⊥
variable range	to 6	over 6 to 10	over 10 to 30	over 30 to 60	over 60 to 100	over 100 to 160	over 160 to 10	over 10 to 100	over 100 to	
tolerance	±0.20	±0.30	±0.50	±0.70	±1.00	±1.30	±1.60	0.10	0.30	0.60

⚠️	ECN NO:240348 Revise the drawing	Gaby	2024/07/23
⚠️	ECN NO:230714 Revise the PART NO.	Benson	2023/09/23
⚠️x1	ECN NO:220814 Revise the PART NO.	Tim	2022/09/16
REV.	ECN NO. OR DESCRIPTION	REVISED	DATE

糧德精密有限公司
Amtek Technology Co., Ltd.
TEL: 886-2-2260-6878
FAX: 886-2-2260-8030

品名 TITLE	TERMINAL BLOCK PCB SCREW 5.00mm DIP V/T TYPE				頁數 Page	1/1
品號 PART NO.	5TS500S-32ANXXXLX-01			繪圖 DRAWN	ERIC 2018/11/21	
圖號 DRAWING NO.	GN011-EA061	版本 REV.	F	核對 CHECKED	JOSH 2018/11/21	
客戶品號 CUSTOMER P/N		比例 SCALE	None	承認 APPROVED	JASON 2018/11/21	
公差 TOLERANCE		單位 UNIT	mm	第三 ANGLE PROJECTION		