

# ORDER INFORMATION

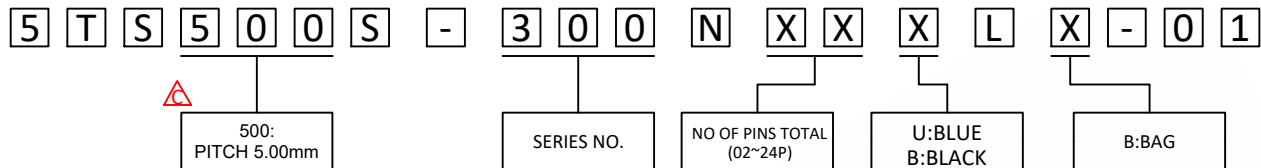

**MATERIAL**

HOUSING: NYLON 66, UL94V-0  
 SPRING: STAINLESS STEEL   
 SCREW: STEEL, M3/ZINC PLATED  
 PIN: COPPER ALLOY, TIN PLATED

**MECHANICAL**

OPERATING TEMPERATURE: -40°C~+105°C  
 SOLDERING TEMPERATURE: 260°C/5S  
 STRIPPING LENGTH: 5~6mm  
 TORQUE: 0.5N·m

**TECHNICAL DATA**

UL/CUL

SAFETY APPROVAL						
USE GROUP	B	C	D			
RATED VOLTAGE (V)	250	-	250			
RATED CURRENT (A)	16	-	10			
WIRE RANGE	22-14					
SOLID/STRANDED (AWG)						
WITHSTANDING VOLTAGE	1500V (1MIN)					

IEC				RECOMMENDED		
OVERVOLTAGE CATEGORY	III	III	II			
CONTAMINATION CLASS	3	2	2			
RATED VOLTAGE (V)	250	400	630			
RATED CURRENT (A)	24	24	24			
IMPULSE WITHSTANDING VOLTAGE (KV)	4.0	4.0	4.0			
CONDUCTOR CROSS SECTION	0.5-2.5					
SOLID/FLEXIBLE (mm <sup>2</sup> )						

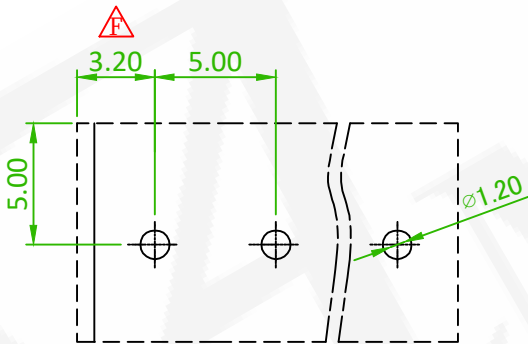

RECOMMENDED PCB LAOUT  
 (PCB TOLERANCE ±0.05)

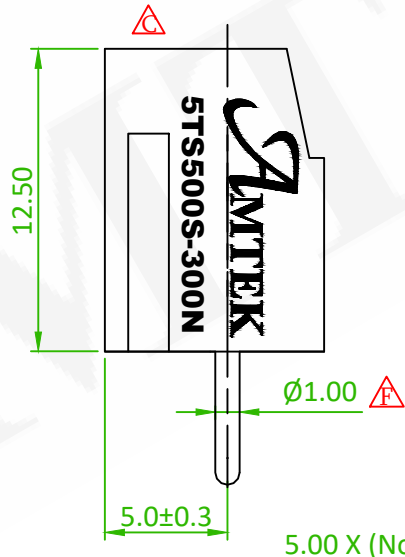
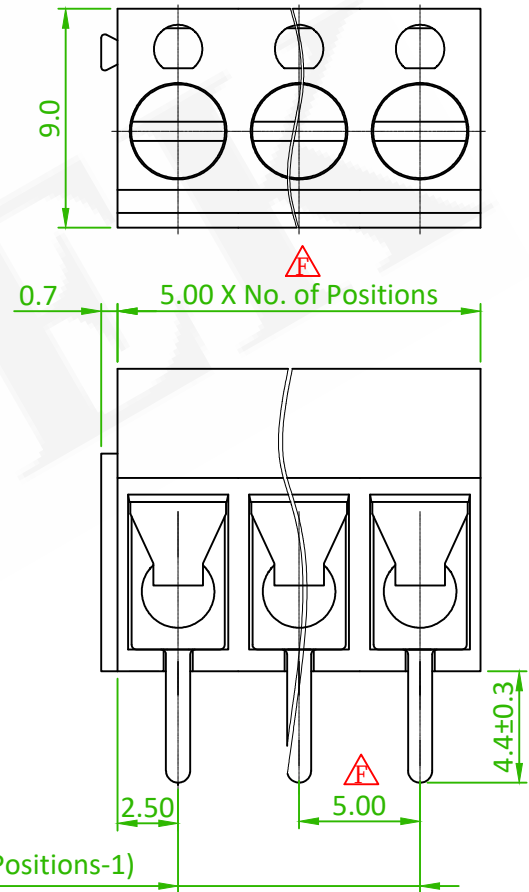

linear dimension (Tolerances Standard GB/T 14486-2008)										—		
variable range	to 6	over 6 to 10	over 10 to 30	over 30 to 60	over 60 to 100	over 100 to 160	over 160 to 10	over 10 to 100	over 100 to 100	over 100 to 100		
tolerance	±0.20	±0.30	±0.50	±0.70	±1.00	±1.30	±1.60	0.10	0.30	0.60		

	ECN 202507059	Willy	2025/08/06
	ECN-202506050	Alice	2025/07/02
	BPM 20250210007	Willy	2025/02/11
REV.	ECN NO. OR DESCRIPTION	REVISED	DATE

糧德精密有限公司  
 Amtek Technology Co., Ltd.  
 TEL: 886-2-2260-6878  
 FAX: 886-2-2260-8030

品名 TITLE	TERMINAL BLOCK PCB SCREW 5.00mm DIP V/T TYPE				頁數 Page	1/1
品號 PART NO.	5TS500S-300NXXXLX-01			繪圖 DRAWN	MIA 2017/01/19	
圖號 DRAWING NO.	GN011-MC235	版本 REV.	G	核對 CHECKED	Jonny 2017/01/19	
客戶品號 CUSTOMER P/N		比例 SCALE	None	承認 APPROVED	Aaron 2017/01/19	
公差 TOLERANCE		單位 UNIT	mm	THIRD ANGLE PROJECTION		