

**MECHANICAL**

TEMP. RANGE: -40°C ~ +105°C  
STEIP LENGTH: 6-7mm  
SOLDERING TEMPERATURE: 260°C/5S

**ORDER INFORMATION**

5 T S 5 0 0 S - 1 6 7 N X X X L X - 0 1

500  
PITCH:5.00mm

SERIES NO.

POLES  
(02-24P)

E:GREEN

A:TRAY  
B:BAG

**MATERIAL**

HOUSING: PA66, UL94V-0  
PIN: COPPER ALLOY, TIN PLATED  
SCREWS: M2.5 STEEL, Zn PLATED, TORQUE:0.4N.m

**TECHNICAL DATA**

UL/CUL

SAFETY APPROVAL			
USE GROUP	B	C	D
RATED VOLTAGE (V)	300	-	300
RATED CURRENT (A)	15	-	10
WIRE RANGE	26-12		
SOLID/STRANDED (AWG)			
WITHSTANDING VOLTAGE	1600V (1MIN)		

IEC **IEC60947-7-4**

OVERVOLTAGE CATEGORY	III	III	II
CONTAMINATION CLASS	3	2	2
RATED VOLTAGE (V)	250	400	630
RATED CURRENT (A)	22	22	22
IMPULSE WITHSTANDING VOLTAGE (KV)	4.0	4.0	4.0
CONDUCTOR CROSS SECTION	0.5-2.5		
SOLID/FLEXIBLE (mm <sup>2</sup> )			

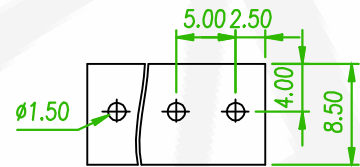
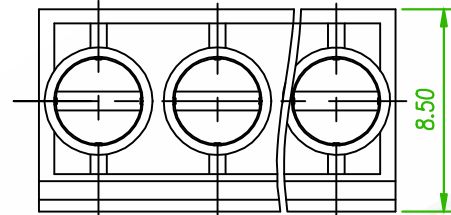

RECOMMENDED PCB LAYOUT  
(PCB TOLERANCE ±0.05)

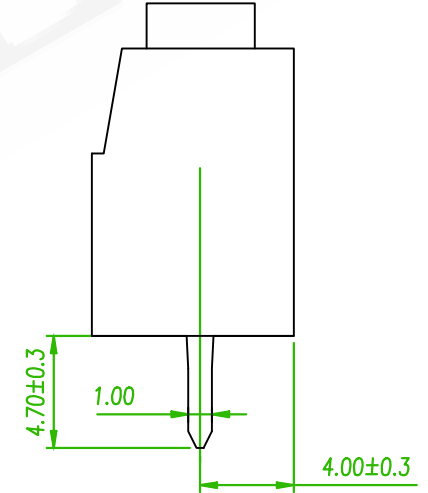
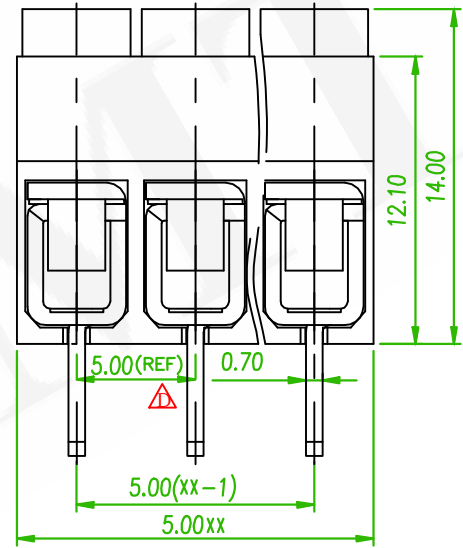

linear dimension(Tolerances Standard GB/T 14486-2008)								—		
variable range	to 6	over 6 to 10	over 10 to 30	over 30 to 60	over 60 to 100	over 100 to 160	over 160 to 10	over 10 to 100	over 100 to 100	
tolerance	±0.20	±0.30	±0.50	±0.70	±1.00	±1.30	±1.60	0.10	0.30	0.60

	ECN-202510038 Revise the drawing	Gaby	2025/11/10
	ECN NO.: 240348 Revise the drawing	Gaby	2024/05/02
	ECN NO:200718 Revise the Tolerance	Alice	2020/12/07
REV.	ECN NO. OR DESCRIPTION	REVISED	DATE

懋德精密有限公司  
Amtek Technology Co., Ltd.  
TEL: 886-2-2260-6878  
FAX: 886-2-2260-8030

品名 TITLE	TERMINAL BLOCK PCB SCREW 5.0mm DIP V/T TYPE				頁數 Page	1/1
品號 PART NO.	5TS500S-167NXXXLX-01			繪圖 DRAWN	ERIC 2018/12/13	
圖號 DRAWING NO.	GN011-EA271	版本 REV.	D	核對 CHECKED	JOSH 2018/12/13	
客戶品號 CUSTOMER P/N		比例 SCALE	None	承認 APPROVED	JASON 2018/12/13	
公差 TOLERANCE		單位 UNIT	mm	第三 ANGLE PROJECTION		