

ORDER INFORMATION

MATERIAL ▲

HOUSING: NYLON66, UL94V-0
CAGE: COPPER ALLOY, M2.5/Ni PLATED
SCREW: STEEL, M2.5/Zn PLATED, TORQUE: 0.4N.m
PIN: COPPER ALLOY, Sn PLATED

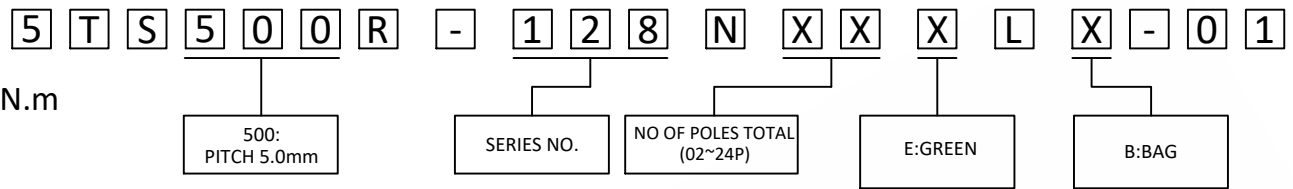

MECHANICAL

OPERATING TEMPERATURE: -40°C~+105°C
SOLDERING TEMPERATURE: 260°C/5S
STRIPPING LENGTH: 6~7

TECHNICAL DATA ▲

UL/CUL

| | | | |
|----------------------|--------------|---|-----|
| SAFETY APPROVAL | | | |
| USE GROUP | B | C | D |
| RATED VOLTAGE (V) | 300 | - | 300 |
| RATED CURRENT (A) | 16 | - | 10 |
| WIRE RANGE | 22-12 | | |
| SOLID/STRANDED (AWG) | | | |
| WITHSTANDING VOLTAGE | 1600V (1MIN) | | |

| | | | |
|---|---------|-----|-----|
| IEC | | | |
| OVERVOLTAGE CATEGORY | III | III | II |
| CONTAMINATION CLASS | 3 | 2 | 2 |
| RATED VOLTAGE (V) | 250 | 400 | 630 |
| RATED CURRENT (A) | 20 | 20 | 20 |
| IMPULSE WITHSTANDING VOLTAGE (KV) | 4.0 | 4.0 | 4.0 |
| CONDUCTOR CROSS SECTION SOLID/FLEXIBLE (mm ²) | 0.5-2.5 | | |

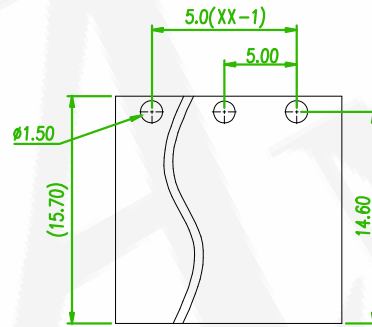

RRCOMMENDED P.C.B LAYOUT
(PCB TOLERANCE±0.1)

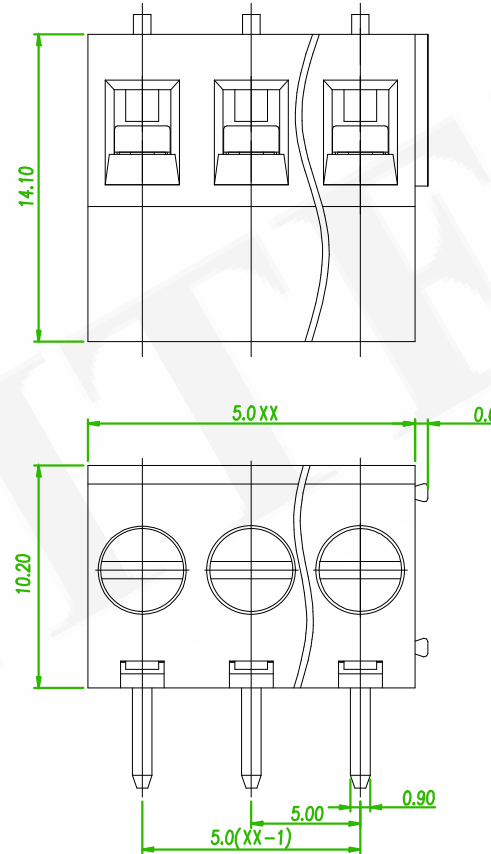

▲

| | | | | | | | | | | |
|--|-------|--------------|---------------|---------------|----------------|-----------------|----------------|----------------|-----------------|------|
| linear dimension (Tolerances Standard GB/T 14486-2008) | | | | | | | | — | | ⊥ |
| variable range | to 6 | over 6 to 10 | over 10 to 30 | over 30 to 60 | over 60 to 100 | over 100 to 160 | over 160 to 10 | over 10 to 100 | over 100 to 100 | |
| tolerance | ±0.20 | ±0.30 | ±0.50 | ±0.70 | ±1.00 | ±1.30 | ±1.60 | 0.10 | 0.30 | 0.60 |

| | | | |
|------------------------------------|------------------------------------|---------|------------|
| ▲ | ECN NO:240348 Revise the drawing | GABY | 2025/01/17 |
| ▲ | ECN NO:200718 Revise the drawing | GABY | 2024/07/17 |
| ▲x1 | ECN NO:200718 Revise the Tolerance | Alice | 2020/12/07 |
| REV. | ECN NO. OR DESCRIPTION | REVISED | DATE |

糧德精密有限公司
Amtek Technology Co., Ltd.
TEL: 886-2-2260-6878
FAX: 886-2-2260-8030

| | | | | | | |
|----------------------|---|-------------|------|---------------------------|---------------------|-----|
| 品名 TITLE | TERMINAL BLOCK PCB SCREW 5.00mm DIP R/A TYPE | | | | 頁數 Page | 1/1 |
| 品號 PART NO. | 5TS500R-128NXXXLX-01 | | | 繪圖 DRAWN | MIA 2017/12/25 | |
| 圖號 DRAWING NO. | GN011-MC845 | 版本 REV. | D | 核對 CHECKED | JOSH 2017/12/25 | |
| 客戶品號 CUSTOMER P/N | | 比例 SCALE | None | 承認 APPROVED | JASON 2017/12/25 | |
| 公差 TOLERANCE | | 單位 UNIT | mm | THIRD ANGLE PROJECTION | | |