

ORDER INFORMATION

MATERIAL B
 HOUSING: NYLON66, UL94V-0
 CAGE: COPPER ALLOY, M2/Ni PLATED
 SCREW: STEEL, M2/Zn PLATED, TORQUE: 0.2N.m
 PIN: COPPER ALLOY, Sn PLATED

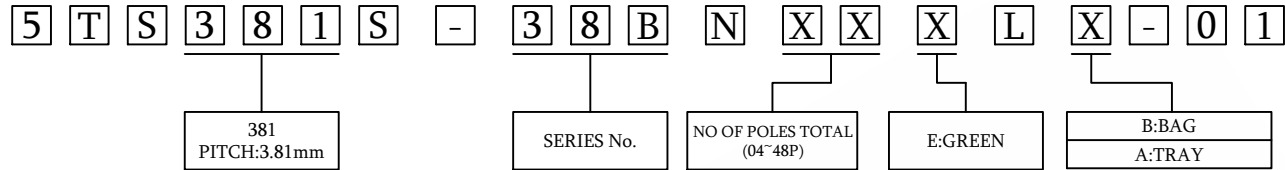

MECHANICAL
 OPERATING TEMPERATURE: -40°C~+105°C
 SOLDERING TEMPERATURE: 260°C/5S
 STRIPPING LENGTH: 4~5mm

TECHNICAL DATA B
 UL/CUL

SAFETY APPROVAL			
USE GROUP	B	C	D
RATED VOLTAGE (V)	300	-	300
RATED CURRENT (A)	10	-	10
WIRE RANGE SOLID/STRANDED (AWG)	28-16		
WITHSTANDING VOLTAGE	1600V (1MIN)		

IEC

SAFETY APPROVAL			
OVERVOLTAGE CATEGORY	III	III	II
CONTAMINATION CLASS	3	2	2
RATED VOLTAGE (V)	160	200	400
RATED CURRENT (A)	13.5	13.5	13.5
IMPULSE WITHSTANDING VOLTAGE (KV)	2.5	2.5	2.5
CONDUCTOR CROSS SECTION SOLID/FLEXIBLE (mm ²)	0.5-1.0		

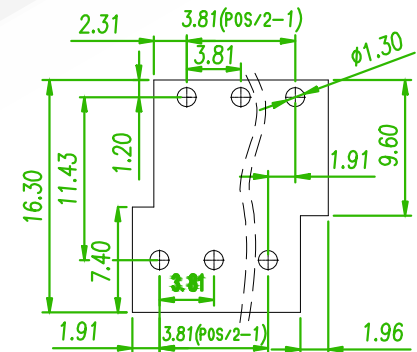
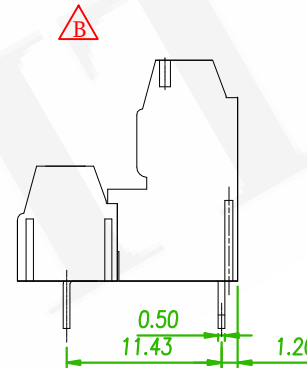
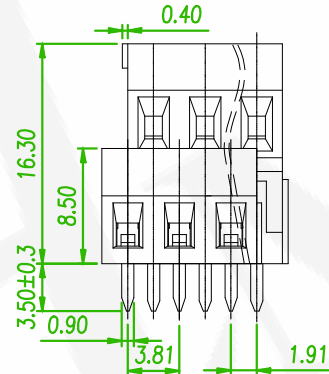
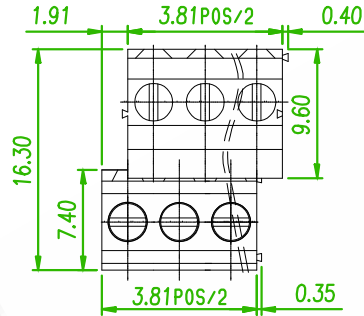

RECOMMENDED PCB LAOUT
(PCB TOLERANCE ±0.05)

B

linear dimension (Tolerances Standard GB/T 14486-2008)								—	∥	⊥
variable range	to 6	over 6 to 10	over 10 to 30	over 30 to 60	over 60 to 100	over 100 to 160	over 160 to 10	over 10 to 100	over 100 to 100	
tolerance	±0.20	±0.30	±0.50	±0.70	±1.00	±1.30	±1.60	0.10	0.30	0.60

C	ECN NO:240348 Revise the drawing	Gaby	2024/08/06
B x1	ECN NO:200718 Revise the Tolerance	Alice	2020/12/25
REV.	ECN NO. OR DESCRIPTION	REVISED	DATE

懋德精密有限公司
Amtek Technology Co., Ltd.
TEL: 886-2-2260-6878
FAX: 886-2-2260-8030

品名 TITLE	TERMINAL BLOCK PCB SCREW 3.81mm DIP V/T TYPE				頁數 Page	1/1
品號 PART NO.	5TS381S-38BNXXXLX-01			繪圖 DRAWN	ERIC 2018/12/07	
圖號 DRAWING NO.	GN011-EA209	版本 REV.	C	核對 CHECKED	JOSH 2018/12/07	
客戶品號 CUSTOMER P/N		比例 SCALE	None	承認 APPROVED	JASON 2018/12/07	
公差 TOLERANCE		單位 UNIT	mm	THIRD ANGLE PROJECTION		