

ORDER INFORMATION

MATERIAL

INSULATOR: NYLON 66, UL94V-0
CAGE: COPPER ALLOY, M2/NICKEL PLATED
SCREW: STEEL, M2/ZINC PLATED, TORQUE: 0.2N.m
TERMINAL: COPPER ALLOY, TIN PLATED

MECHANICAL

OPERATING TEMPERATURE: -40°C~+105°C
SOLDERING TEMPERATURE: 260°C/5S
STRIPPING LENGTH: 4~5mm

TECHNICAL DATA

UL/CUL

SAFETY APPROVAL			
USE GROUP	B	C	D
RATED VOLTAGE (V)	300	-	300
RATED CURRENT (A)	10	-	10
WIRE RANGE SOLID/STRANDED (AWG)	28-16		
WITHSTANDING VOLTAGE	1600V (1MIN)		

IEC

SAFETY APPROVAL			
OVERVOLTAGE CATEGORY	III	III	II
CONTAMINATION CLASS	3	2	2
RATED VOLTAGE (V)	160	200	400
RATED CURRENT (A)	13.5	13.5	13.5
IMPULSE WITHSTANDING VOLTAGE (KV)	2.5	2.5	2.5
CONDUCTOR CROSS SECTION SOLID/FLEXIBLE (mm ²)	0.5-1.0		

5 T S 3 8 1 S - 3 8 1 N X X X L X - 0 1

NO OF POLES TOTAL (02~24P)

E: GREEN
B: BLACK

B: BAG (FOR 2~3P)

X: BOX (FOR 4~24P)

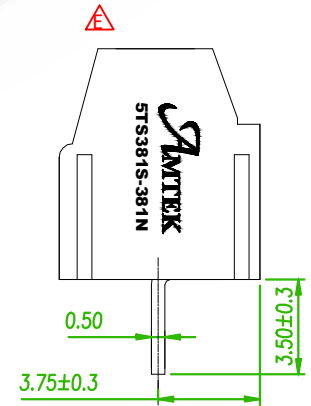
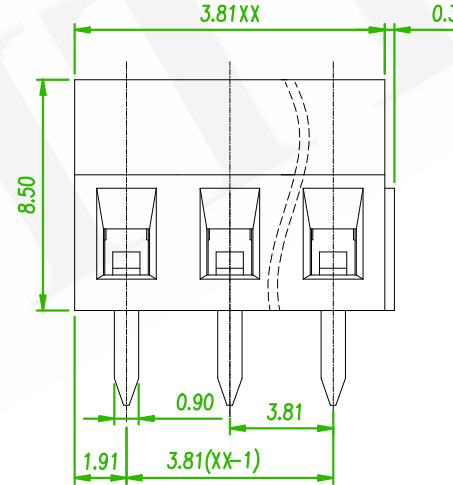
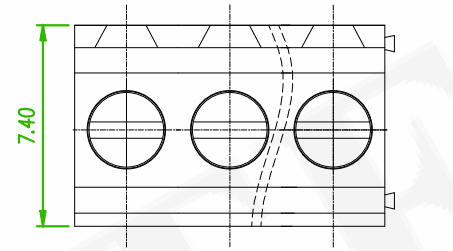
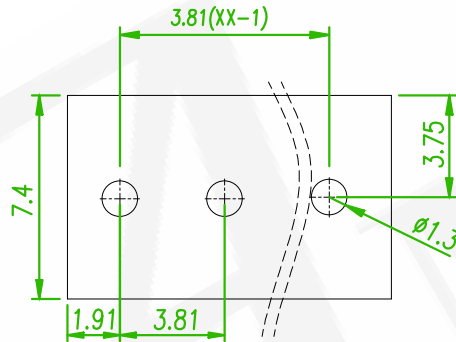

linear dimension (Tolerances Standard GB/T 14486-2008)

		over 6	over 10	over 30	over 60	over 100	over 160		over 10	over 100
variable range	to 6	to 10	to 30	to 60	to 100	to 160	to 10	to 100	to 100	to 100
tolerance	±0.20	±0.30	±0.50	±0.70	±1.00	±1.30	±1.60	0.10	0.30	0.60

	ECN 202605040	Willy	2026/06/08
	ECN NO:240348 Add the drawing	Gaby	2024/08/02
	Add the Color options	Benson	2022/06/06
REV.	ECN NO. OR DESCRIPTION	REVISED	DATE

懌德精密有限公司
Amtek Technology Co., Ltd.
TEL: 886-2-2260-6878
FAX: 886-2-2260-8030

品名 TITLE	TERMINAL BLOCK PCB SCREW 3.81mm DIP V/T TYPE			頁數 Page	1/1
品號 PART NO.	5TS381S-381NXXXLX-01			繪圖 DRAWN	Roy 2016/02/18
圖號 DRAWING NO.	GN011-AL622	版本 REV.	F	核對 CHECKED	Tammy 2016/02/18
客戶品號 CUSTOMER P/N		比例 SCALE	None	承認 APPROVED	John 2016/02/18
公差 TOLERANCE		單位 UNIT	mm	THIRD ANGLE PROJECTION	