

MATERIAL

HOUSING: NYLON66, UL94V-0
 CAGE: COPPER ALLOY, M2/Ni PLATED
 SCREW: STEEL, M2/Zn PLATED, TORQUE: 0.2N.m
 PIN: COPPER ALLOY, Sn PLATED

MECHANICAL

OPERATING TEMPERATURE: -40°C~+105°C
 SOLDERING TEMPERATURE: 260°C/5S
 STRIPPING LENGTH: 4~5mm

TECHNICAL DATA

SAFETY APPROVAL			
USE GROUP	B	C	D
RATED VOLTAGE (V)	300	-	300
RATED CURRENT (A)	10	-	10
WIRE RANGE	28-16		
SOLID/STRANDED (AWG)	28-16		
WITHSTANDING VOLTAGE	1600V (1MIN)		

IEC

SAFETY APPROVAL			
OVERVOLTAGE CATEGORY	III	III	II
CONTAMINATION CLASS	3	2	2
RATED VOLTAGE (V)	160	200	400
RATED CURRENT (A)	13.5	13.5	13.5
IMPULSE WITHSTANDING VOLTAGE (KV)	2.5	2.5	2.5
CONDUCTOR CROSS SECTION	0.5-1.0		
SOLID/FLEXIBLE (mm ²)	0.5-1.0		

ORDER INFORMATION

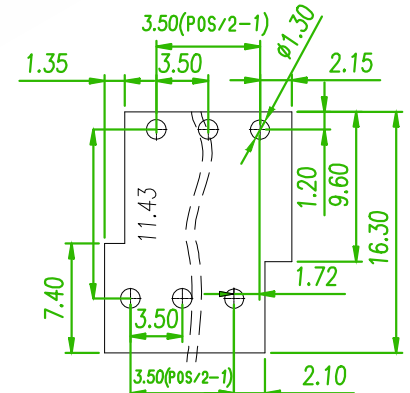
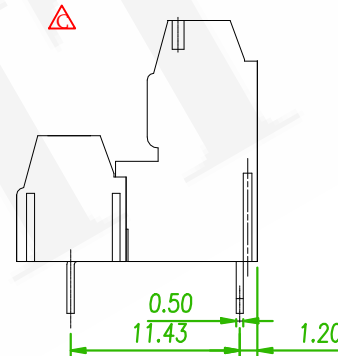
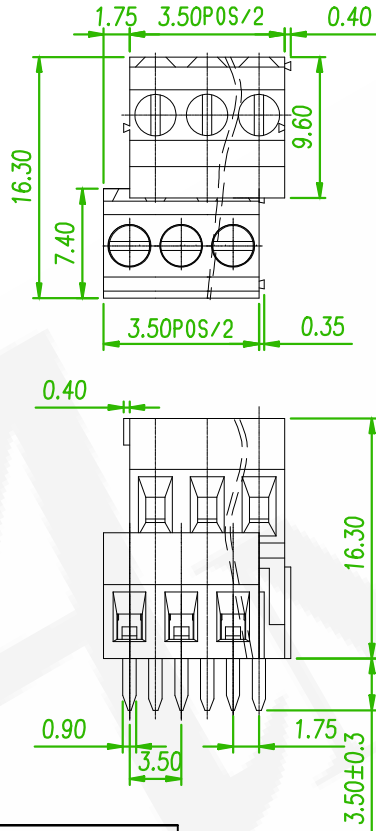
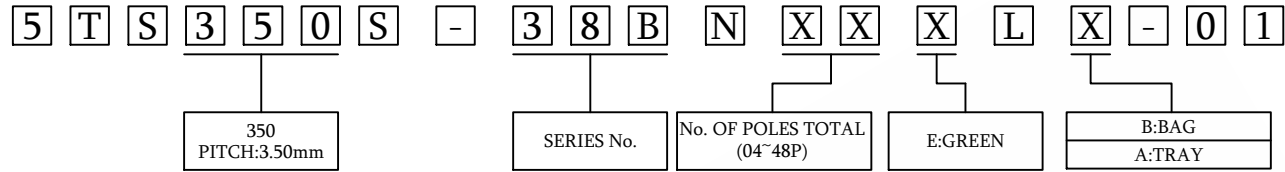

linear dimension (Tolerances Standard GB/T 14486-2008)								—		
variable range	to 6	over 6 to 10	over 10 to 30	over 30 to 60	over 60 to 100	over 100 to 160	over 160 to 300	to 10	over 10 to 100	over 100 to 300
tolerance	±0.20	±0.30	±0.50	±0.70	±1.00	±1.30	±1.60	0.10	0.30	0.60

	ECN NO:240348 Revise the drawing	Gaby	2024/08/06
	ECN NO:200718 Revise the Tolerance	Alice	2020/12/25
REV.	ECN NO. OR DESCRIPTION	REVISED	DATE

 糧德精密有限公司 Amtek Technology Co., Ltd. TEL: 886-2-2260-6878 FAX: 886-2-2260-8030	品名 TITLE	TERMINAL BLOCK PCB SCREW 3.50mm DIP V/T TYPE			頁數 Page	1/1
	品號 PART NO.	5TS350S-38BNXXXLX-01			繪圖 DRAWN	ERIC 2018/12/07
	圖號 DRAWING NO.	GN011-EA208	版本 REV.	C	核對 CHECKED	JOSH 2018/12/07
	客戶品號 CUSTOMER P/N		比例 SCALE	None	承認 APPROVED	JASON 2018/12/07
	公差 TOLERANCE		單位 UNIT	mm	THIRD ANGLE PROJECTION	

