

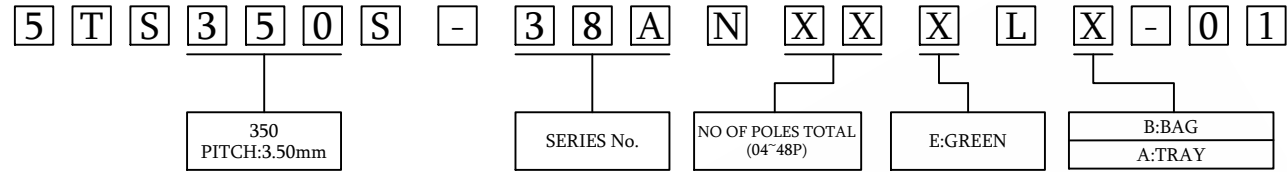

MATERIAL 
 HOUSING: NYLON66, UL94V-0
 CAGE: COPPER ALLOY, M2/Ni PLATED
 SCREW: STEEL, M2/Zn PLATED, TORQUE: 0.2N.m
 PIN: COPPER ALLOY, Sn PLATED

ORDER INFORMATION



MECHANICAL
 OPERATING TEMPERATURE: -40°C~+105°C
 SOLDERING TEMPERATURE: 260°C/5S
 STRIPPING LENGTH: 4~5mm

TECHNICAL DATA 
 UL/CUL

| | | | |
|----------------------|---|---|-----|
| SAFETY APPROVAL |  | | |
| USE GROUP | B | C | D |
| RATED VOLTAGE (V) | 300 | - | 300 |
| RATED CURRENT (A) | 10 | - | 10 |
| WIRE RANGE | 28-16 | | |
| SOLID/STRANDED (AWG) | 28-16 | | |
| WITHSTANDING VOLTAGE | 1600V (1MIN) | | |

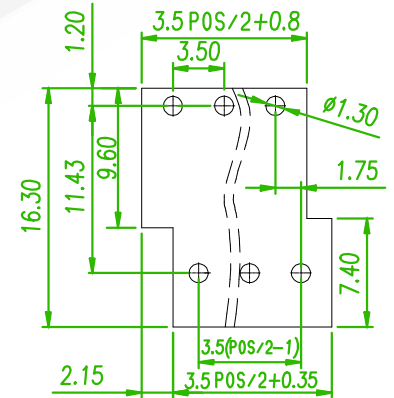
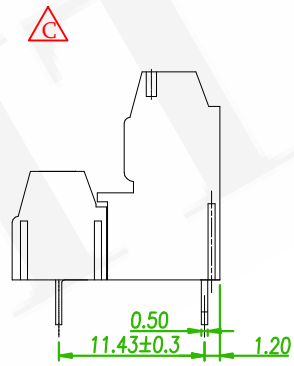
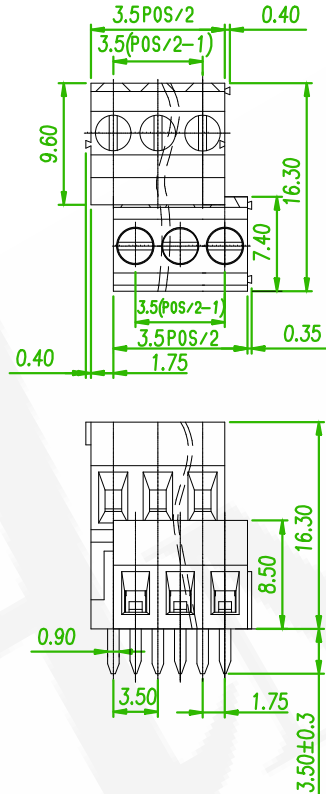

IEC

| | | | |
|-----------------------------------|---|------|------|
| SAFETY APPROVAL |  | | |
| OVERVOLTAGE CATEGORY | III | III | II |
| CONTAMINATION CLASS | 3 | 2 | 2 |
| RATED VOLTAGE (V) | 160 | 200 | 400 |
| RATED CURRENT (A) | 13.5 | 13.5 | 13.5 |
| IMPULSE WITHSTANDING VOLTAGE (KV) | 2.5 | 2.5 | 2.5 |
| CONDUCTOR CROSS SECTION | 0.5-1.0 | | |
| SOLID/FLEXIBLE (mm ²) | 0.5-1.0 | | |





| | | | | | | | | | | |
|---|-------|--------------|---------------|---------------|----------------|-----------------|-----------------|------------------|-------------------|--------------------|
| linear dimension(Tolerances Standard GB/T 14486-2008) | | | | | | | | — | ▱ | ⊥ |
| variable range | to 6 | over 6 to 10 | over 10 to 30 | over 30 to 60 | over 60 to 100 | over 100 to 160 | over 160 to 300 | over 300 to 1000 | over 1000 to 3000 | over 3000 to 10000 |
| tolerance | ±0.20 | ±0.30 | ±0.50 | ±0.70 | ±1.00 | ±1.30 | ±1.60 | 0.10 | 0.30 | 0.60 |

| | | | |
|---|------------------------------------|---------|------------|
|  | ECN NO:240348 Revise the drawing | Gaby | 2024/08/05 |
|  | ECN NO:200718 Revise the Tolerance | Alice | 2020/12/25 |
| REV. | ECN NO. OR DESCRIPTION | REVISED | DATE |



糧德精密有限公司
 Amtek Technology Co., Ltd.
 TEL: 886-2-2260-6878
 FAX: 886-2-2260-8030

| | | | | | | |
|----------------------|--|-------------|------|------------------------|---|-----|
| 品名 TITLE | TERMINAL BLOCK PCB SCREW 3.50mm DIP V/T TYPE | | | | 頁數 Page | 1/1 |
| 品號 PART NO. | 5TS350S-38ANXXXLX-01 | | | 繪圖 DRAWN | ERIC | |
| 圖號 DRAWING NO. | GN011-EA206 | 版本 REV. | C | 核對 CHECKED | JOSH | |
| 客戶品號 CUSTOMER P/N | | 比例 SCALE | None | 承認 APPROVED | JASON | |
| 公差 TOLERANCE | | 單位 UNIT | mm | THIRD ANGLE PROJECTION |  | |