

**MATERIAL**

HOUSING: NYLON66, UL94V-0  
 COVER: NYLON66, UL94V-0  
 CAGE: COPPER ALLOY, M2/Ni PLATED  
 SCREW: STEEL, M2, TORQUE: 0.2N.m  
 PIN: COPPER ALLOY, Sn PLATED

**ORDER INFORMATION**

5 T S 3 5 0 L - 5 X D N X X X L X - 0 1

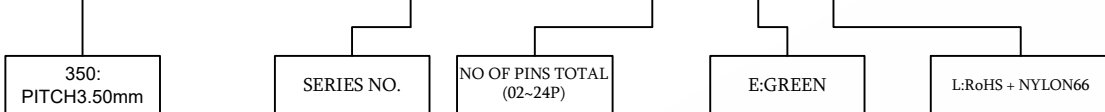

**MECHANICAL**

OPERATING TEMPERATURE: -40°C ~ +105°C  
 SOLDERING TEMPERATURE: 260°C/5S  
 STRIPPING LENGTH: 5mm

**TECHNICAL DATA**

UL/CUL

SAFETY APPROVAL			
USE GROUP	B	C	D
RATED VOLTAGE (V)	300	-	300
RATED CURRENT (A)	10	-	10
WIRE RANGE	26-16		
SOLID/STRANDED (AWG)			
WITHSTANDING VOLTAGE	1600V (1MIN)		

IEC

OVERVOLTAGE CATEGORY	III	III	II
CONTAMINATION CLASS	3	2	2
RATED VOLTAGE (V)	160	200	400
RATED CURRENT (A)	10	10	10
IMPULSE WITHSTANDING VOLTAGE (KV)	2.5	2.5	2.5
CONDUCTOR CROSS SECTION SOLID/FLEXIBLE (mm <sup>2</sup> )	0.2-1.5		

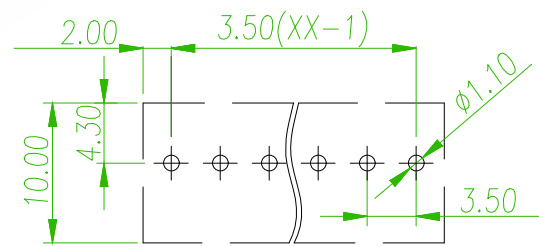
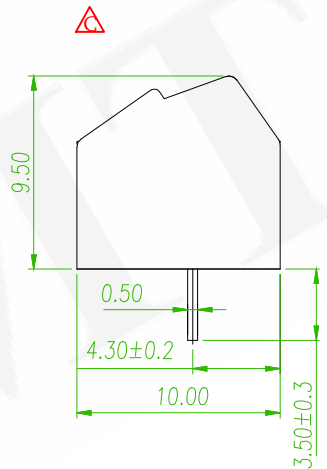
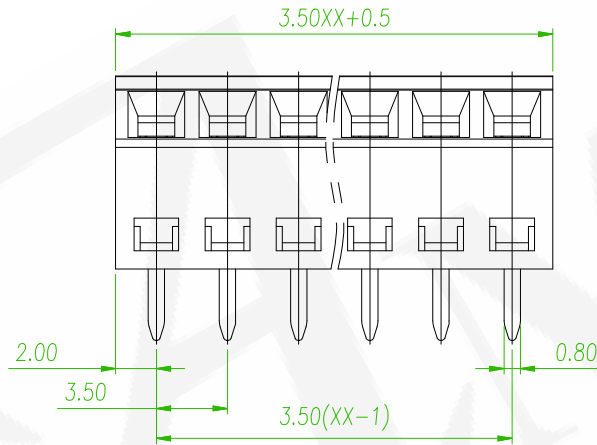
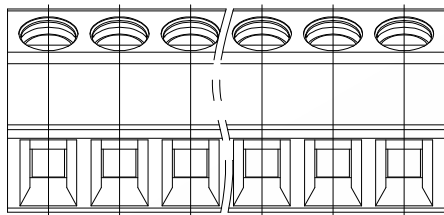

RECOMMENDED PCB LAOUT (PCB TOLERANCE ±0.05)



linear dimension (Tolerances Standard GB/T 14486-2008)							—		⊥	
variable range	to 6	over 6 to 10	over 10 to 30	over 30 to 60	over 60 to 100	over 100 to 160	to 10	over 10 to 100	over 100 to	
tolerance	±0.20	±0.30	±0.50	±0.70	±1.00	±1.30	±1.60	0.10	0.30	0.60

	ECN NO:240348 Revise the drawing	Gaby	2024/08/02
	ECN NO:200718 Revise the Tolerance	Alice	2020/12/04
REV.	ECN NO. OR DESCRIPTION	REVISED	DATE

糧德精密有限公司  
 Amtek Technology Co., Ltd.  
 TEL: 886-2-2260-6878  
 FAX: 886-2-2260-8030

品名 TITLE	TERMINAL BLOCK PCB SCREW 3.50mm				頁數 Page	1/1
品號 PART NO.	5TS350L-5XDNXXXLX-01			繪圖 DRAWN	Roy 2017/09/01	
圖號 DRAWING NO.	GN011-RL982	版本 REV.	C	核對 CHECKED	Carol 2017/09/01	
客戶品號 CUSTOMER P/N		比例 SCALE	None	承認 APPROVED	Jason 2017/09/01	
公差 TOLERANCE		單位 UNIT	mm	THIRD ANGLE PROJECTION		