

MATERIAL ⚠️
 HOUSING: NYLON66, UL94V-0
 CAGE: STEEL, M5
 SCREW: STEEL, M5, TORQUE: 2.0N.m
 PIN: COPPER ALLOY, Sn PLATED

ORDER INFORMATION

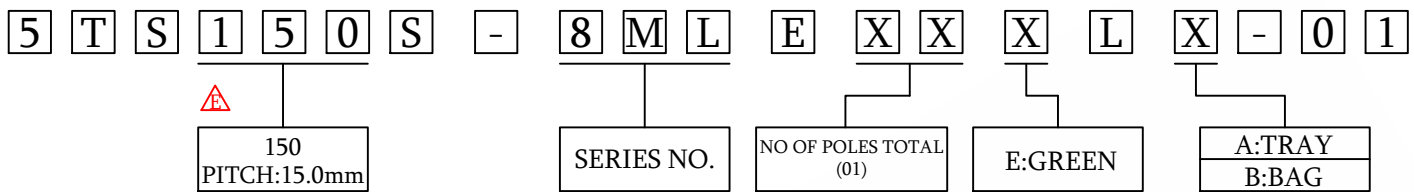

MECHANICAL
 OPERATING TEMPERATURE: -40°C~+105°C
 SOLDERING TEMPERATURE: 260°C/5S
 STRIPPING LENGTH: 17~18

TECHNICAL DATA

UL/CUL

SAFETY APPROVAL			
USE GROUP	B	C	D
RATED VOLTAGE (V)	600	600	600
RATED CURRENT (A)	115	115	5
WIRE RANGE	20-2		
SOLID/STRANDED (AWG)	20-2		
WITHSTANDING VOLTAGE	2200V (1MIN)		

IEC **EN60774**

OVERVOLTAGE CATEGORY	III	III	II
CONTAMINATION CLASS	3	2	2
RATED VOLTAGE (V)	1000	1000	1000
RATED CURRENT (A)	125	125	125
IMPULSE WITHSTANDING VOLTAGE (KV)	8.0	8.0	8.0
CONDUCTOR CROSS SECTION SOLID/FLEXIBLE (mm ²)	0.5-35		

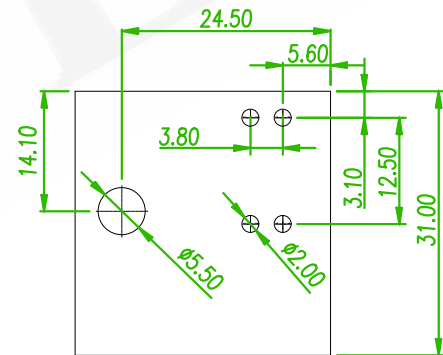
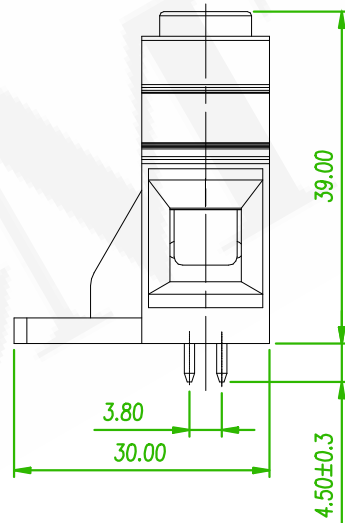
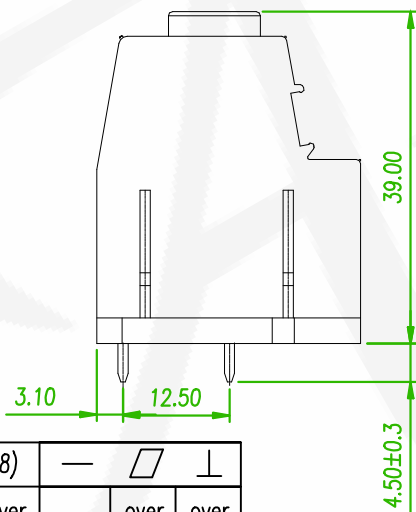
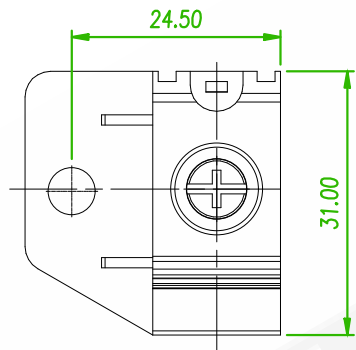

RECOMMENDED PCB LAOUT (PCB TOLERANCE ±0.05)

⚠️

linear dimension (Tolerances Standard GB/T 14486-2008)									
variable range	to 6	over 6 to 10	over 10 to 30	over 30 to 60	over 60 to 100	over 100 to 160	over 160 to 10	over 10 to 100	over 100 to 100
tolerance	±0.20	±0.30	±0.50	±0.70	±1.00	±1.30	±1.60	0.10	0.30

⚠️	ECN NO:240348 Revise the drawing	Gaby	2024/08/01
⚠️	ECN NO:230714 Revise the PART NO.	Randy	2023/09/23
⚠️x2	ECN NO:201214 Revise the PART NO.	Alice	2020/12/29
REV.	ECN NO. OR DESCRIPTION	REVISED	DATE

懋德精密有限公司
 Amtek Technology Co., Ltd.
 TEL: 886-2-2260-6878
 FAX: 886-2-2260-8030

品名 TITLE	TERMINAL BLOCK PCB SCREW 1.50mm DIP V/T TYPE				頁數 Page	1/1
品號 PART NO.	5TS150S-8MLEXXXLX-01			繪圖 DRAWN	Eric 2018/11/26	
圖號 DRAWING NO.	GN011-EA095	版本 REV.	E	核對 CHECKED	Jason 2018/11/26	
客戶品號 CUSTOMER P/N		比例 SCALE	None	承認 APPROVED	JOSH 2018/11/26	
公差 TOLERANCE		單位 UNIT	mm	THIRD ANGLE PROJECTION		