

**MATERIAL** ⚠

HOUSING: NYLON66, UL94V-0  
 CAGE: STEEL, M5/Zn PLATED  
 SCREW: STEEL, M5/Zn PLATED, TORQUE: 2.0N.m  
 PIN: COPPER ALLOY, Sn PLATED

**ORDER INFORMATION**

5 T S 1 5 0 S - 1 1 8 N X X X L X - 0 1



NO OF POLES (01-12P)      E: GREEN      A: TRAY  
 B: BAG

**MECHANICAL**

OPERATING TEMPERATURE: -40°C~+105°C  
 SOLDERING TEMPERATURE: 260°C/5S  
 STRIPPING LENGTH: 17~18

**TECHNICAL DATA** ⚠

UL/CUL

SAFETY APPROVAL			
USE GROUP	B	C	D
RATED VOLTAGE (V)	600	600	600
RATED CURRENT (A)	115	115	5
WIRE RANGE	20-2		
SOLID/STRANDED (AWG)	20-2		
WITHSTANDING VOLTAGE	2200V (1MIN)		

IEC			
OVERVOLTAGE CATEGORY	III	III	II
CONTAMINATION CLASS	3	2	2
RATED VOLTAGE (V)	1000	1000	1000
RATED CURRENT (A)	125	125	125
IMPULSE WITHSTANDING VOLTAGE (KV)	8.0	8.0	8.0
CONDUCTOR CROSS SECTION	0.5-35		
SOLID/FLEXIBLE (mm <sup>2</sup> )	0.5-35		

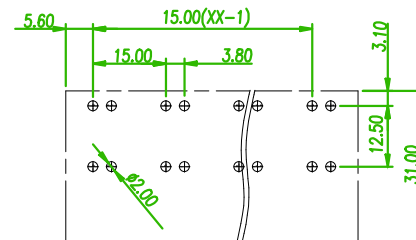
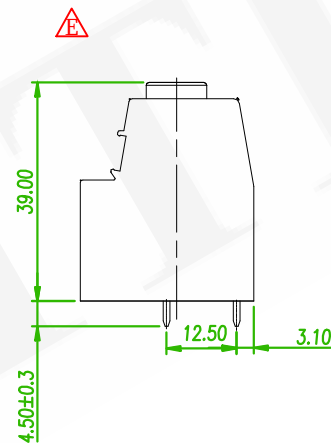
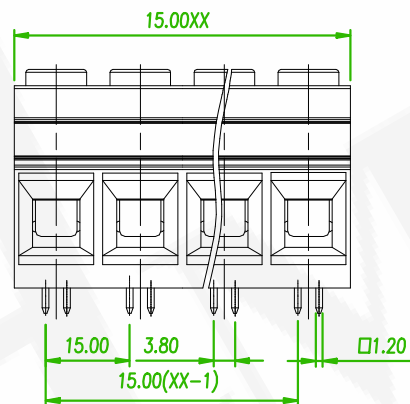
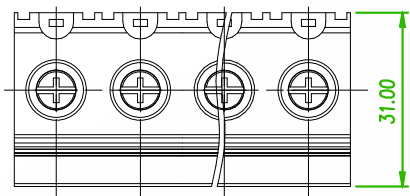

RECOMMENDED PCB LAOUT (PCB TOLERANCE ±0.05)

linear dimension (Tolerances Standard GB/T 14486-2008)									
variable range	to 6	over 6 to 10	over 10 to 30	over 30 to 60	over 60 to 100	over 100 to 160	to 10	over 10 to 100	to 100
tolerance	±0.20	±0.30	±0.50	±0.70	±1.00	±1.30	±1.60	0.10	0.30

⚠	ECN 202511023	Willy	2025/11/27
⚠	ECN NO:240348 Revise the drawing	Gaby	2024/08/01
⚠	ECN NO:230714 Revise the PART NO.	Randy	2023/09/23
REV.	ECN NO. OR DESCRIPTION	REVISED	DATE

糧德精密有限公司  
 Amtek Technology Co., Ltd.  
 TEL: 886-2-2260-6878  
 FAX: 886-2-2260-8030

品名 TITLE	TERMINAL BLOCK PCB SCREW 15.0mm				頁數 Page	1/1
品號 PART NO.	5TS150S-118NXXXLX-01			繪圖 DRAWN	Eric 2018/11/26	
圖號 DRAWING NO.	GN011-EA093	版本 REV.	F	核對 CHECKED	JOSH 2018/11/26	
客戶品號 CUSTOMER P/N		比例 SCALE	None	承認 APPROVED	JOSH 2018/11/26	
公差 TOLERANCE		單位 UNIT	mm	第三 ANGLE PROJECTION		