

**MATERIAL**   
 HOUSING: NYLON66, UL94V-0  
 CAGE: STEEL, M4  
 SCREW: STEEL, M4, TORQUE: 1.2N.m  
 PIN: COPPER ALLOY, Sn PLATED

## ORDER INFORMATION

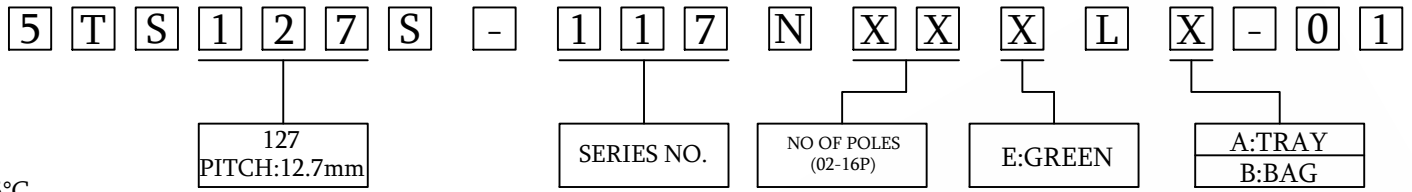

### MECHANICAL

OPERATING TEMPERATURE: -40°C~+105°C  
 SOLDERING TEMPERATURE: 260°C/5S  
 STRIPPING LENGTH: 11~12

### TECHNICAL DATA

UL/CUL

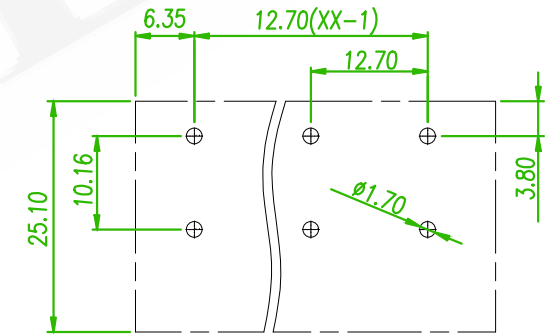
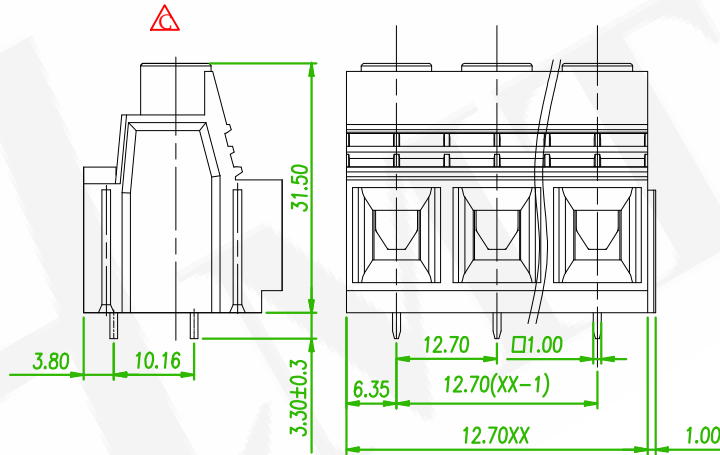
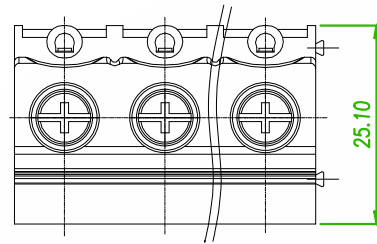

SAFETY APPROVAL			
USE GROUP	B	C	D
RATED VOLTAGE (V)	600	600	600
RATED CURRENT (A)	65	65	5
WIRE RANGE SOLID/STRANDED (AWG)	20-6		
WITHSTANDING VOLTAGE	2200V (1MIN)		

IEC	IEC60077-4		
OVERVOLTAGE CATEGORY	III	III	II
CONTAMINATION CLASS	3	2	2
RATED VOLTAGE (V)	1000	1000	1000
RATED CURRENT (A)	57	57	57
IMPULSE WITHSTANDING VOLTAGE (KV)	8.0	8.0	8.0
CONDUCTOR CROSS SECTION SOLID/FLEXIBLE (mm <sup>2</sup> )	2.5-16		



RECOMMENDED PCB LAOUT  
 (PCB TOLERANCE ±0.05)





linear dimension (Tolerances Standard GB/T 14486-2008)								—		
variable range	to 6	over 6 to 10	over 10 to 30	over 30 to 60	over 60 to 100	over 100 to 160	over 160 to	to 10	over 10 to 100	over 100 to
tolerance	±0.20	±0.30	±0.50	±0.70	±1.00	±1.30	±1.60	0.10	0.30	0.60



**糧德精密有限公司**  
 Amtek Technology Co., Ltd.  
 TEL: 886-2-2260-6878  
 FAX: 886-2-2260-8030

品名 TITLE	TERMINAL BLOCK PCB SCREW 12.7mm				頁數 Page	1/1
品號 PART NO.	5TS127S-117NXXXLX-01			繪圖 DRAWN	Eric 2018/11/26	
圖號 DRAWING NO.	GN011-EA096	版本 REV.	C	核對 CHECKED	JOSH 2018/11/26	
客戶品號 CUSTOMER P/N		比例 SCALE	None	承認 APPROVED	Jason 2018/11/26	
公差 TOLERANCE		單位 UNIT	mm	THIRD ANGLE PROJECTION		

	ECN NO:240348 Revise the drawing	Gaby	2024/08/01
	ECN NO:200718 Revise the Tolerance	Alice	2020/12/04
REV.	ECN NO. OR DESCRIPTION	REVISED	DATE