

ORDER INFORMATION

ELECTRICAL

STANDARD: UL
 RATED VOLTAGE: 300V
 RATED CURRENT: 20A
 CONTACT RESISTANCE: 20mΩ
 WITHSTANDING VOLTAGE: AC 1600V FOR ONE MIN
 INSULATION RESISTANCE: 500MΩ/DC500V
 WIRE RANGE: 22-12AWG

5 T B 9 5 0 S - 4 5 S N X X X L X - W 1

950
PITCH:9.50mm

SERIES No.

POLES
(02-24P)

B:BLACK

A:TRAY
B:BAG

MECHANICAL

TEMP. RANGE: -40°C ~ +105°C
 TORQUE: 1.2Nm
 MAX SOLDERING: +260°C ,FOR 5 SEC

MATERIAL

HOUSING: NYLON66, UL94V-0
 SCREWS: STEEL, M4 STEEL Ni PLATED
 PIN HEADER: COPPER ALLOY, Sn PLATED

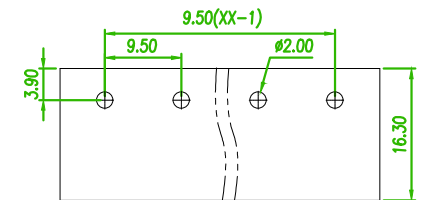
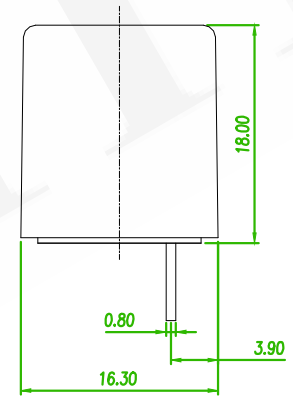
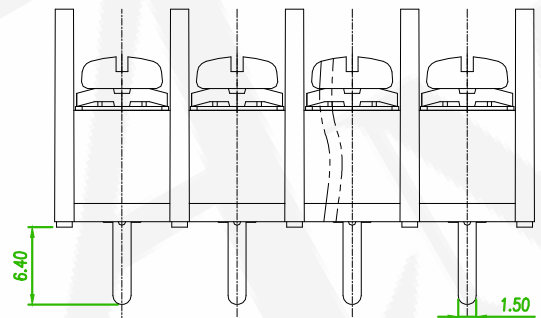
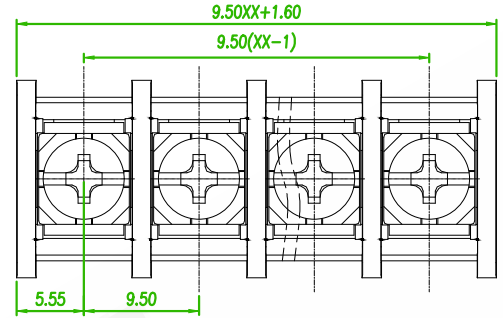

RECOMMENDED PCB LAOUT
(PCB TOLERANCE ±0.05)

linear dimension(Tolerances Standard GB/T 14486-2008)								—	∕	⊥
variable range	to 6	over 6 to 10	over 10 to 30	over 30 to 60	over 60 to 100	over 100 to 160	over 160 to 10	over 10 to 100	over 100 to	
tolerance	±0.20	±0.30	±0.50	±0.70	±1.00	±1.30	±1.60	0.10	0.30	0.60

△D	ECN NO:240348 Revises the drawing	Gaby	2024/12/03
△Cx3	ECN NO:200718 Revise the Tolerance & ECN NO:201211 Revise the PART NO.	Alice	2020/12/23
△Bx1	ECN 200102: Remove the IEC	David	2020/06/06
REV.	ECN NO. OR DESCRIPTION	REVISED	DATE

糧德精密有限公司
Amtek Technology Co., Ltd.
TEL: 886-2-2260-6878
FAX: 886-2-2260-8030

品名 TITLE	TERMINAL BLOCK BARRIER 9.5mm DIP V/T TYPE				頁數 Page	1/1
品號 PART NO.	5TB950S-45SNXXXLX-W1				繪圖 DRAWN	Eric 2019/01/11
圖號 DRAWING NO.	GN011-EA563	版本 REV.	D	核對 CHECKED	Josh 2019/01/11	
客戶品號 CUSTOMER P/N		比例 SCALE	None	承認 APPROVED	Jason 2019/01/11	
公差 TOLERANCE		單位 UNIT	mm	THIRD ANGLE PROJECTION		