

ORDER INFORMATION

5 T B 1 0 0 S - 5 5 C N X X X L X - W 1

ELECTRICAL

STANDARD: UL
 RATED VOLTAGE: 300V
 RATED CURRENT: 25A
 CONTACT RESISTANCE: 20mΩ
 INSULATION RESISTANCE: 500MΩ / DC 500V
 WIRE RANGE: 22~12AWG
 WITHSTANDING VOLTAGE: AC 1600V FOR ONE MIN

MECHANICAL

TEMP. RANGE: -40°C ~ +105°C
 TORQUE: 1.2Nm
 MAX SOLDERING: +260°C, FOR 5 SEC

MATERIAL

HOUSING: NYLON66, UL94V-0
 SCREWS: STEEL, M4 STEEL Ni PLATED
 PIN HEADER: COPPER ALLOY, Sn PLATED

NO OF PINS TOTAL
(02-24P)

B:BLACK

B:BAG

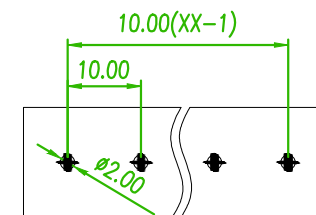
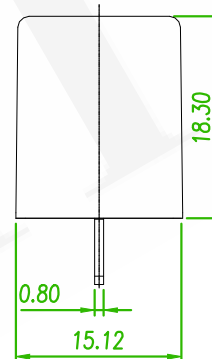
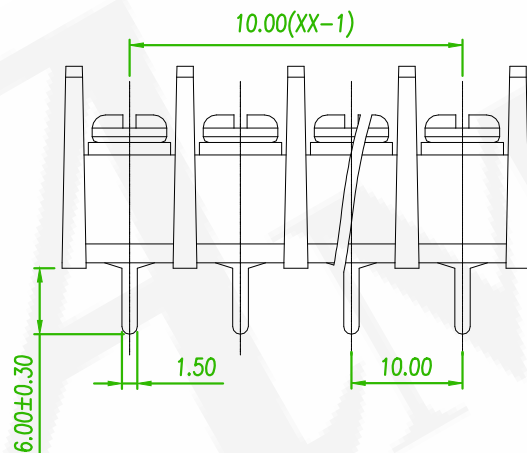
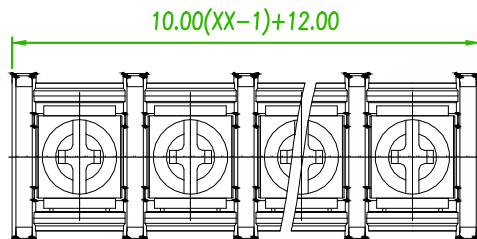

RECOMMENDED PCB LAOUT
(PCB TOLERANCE ±0.05)

linear dimension(Tolerances Standard GB/T 14486-2008)							—	∕	⊥	
variable range	to 6	over 6 to 10	over 10 to 30	over 30 to 60	over 60 to 100	over 100 to 160	to 10	over 10 to 100	over 100 to	
tolerance	±0.20	±0.30	±0.50	±0.70	±1.00	±1.30	±1.60	0.10	0.30	0.60

△	ECN-202601002	Oliver	2026/01/14
△	ECN NO:240348 REVISE THE DRAWING	Gaby	2024/12/04
△x2	ECN NO:201211 REVISE THE PART NO.	Alice	2020/12/31
REV.	ECN NO. OR DESCRIPTION	REVISED	DATE

懌德精密有限公司
Amtek Technology Co., Ltd.
TEL: 886-2-2260-6878
FAX: 886-2-2260-8030

品名 TITLE	TERMINAL BLOCK BARRIER 10.0mm			頁數 Page	1/1
品號 PART NO.	△ 5TB100S-55CNXXXLX-W1			繪圖 DRAWN	Joe 2010/01/26
圖號 DRAWING NO.	GN011-MC469	版本 REV.	F	核對 CHECKED	Paul 2010/01/26
客戶品號 CUSTOMER P/N		比例 SCALE	None	承認 APPROVED	James 2010/01/26
公差 TOLERANCE		單位 UNIT	mm	THIRD ANGLE PROJECTION	☉ ↯