

SPECIFICATIONS

DIELECTRIC STRENGTH: AC250V /1MIN
 RATING:DC12V,50mA MAX
 CONTACT RESISTANCE:100mΩ MAX
 INSULATION RESISTANCE:100MΩ MIN
 OPERATING LIFE:100,000 CYCLES
 OPERATING FORCE:160gf±30gf OR 250gf±50gf OR 400gf±100gf

ORDER INFORMATION

6 S T M S 2 3 - X X X X X X X X A 0 X

031:3.1mm	160:160gf±30gf	N:BROWN	N:W/O PEG W/O GROUND WITH SHELL	H:T/R W/O CAP	1:FLAT TYPE 2:U TYPE
	250:250gf±50gf				
	400:400gf±100gf				

AMTEK 糧德
 2025.11.05
 Released DCC

MATERIALS

BASE:NYLON 6T,BLACK
 TERMINAL:BRASS,SILVER PLATED
 CONTACT:STAINLESS STEEL,SILVER PLATED
 COVER:STAINLESS STEEL
 ACTUATOR:PPA
 TAPE SEALED:PI
 INTERNAL PRESSER:PPA,BLACK

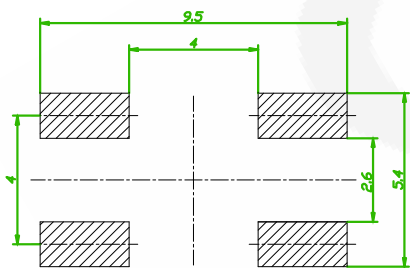
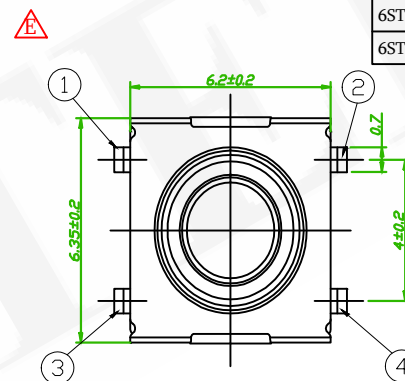
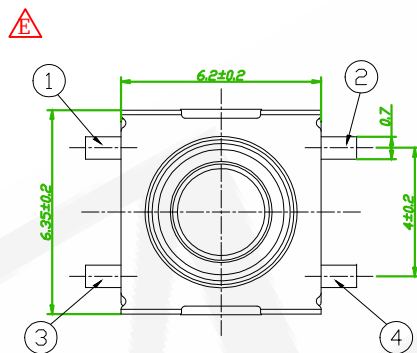
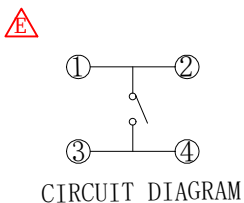

RECOMMENDED PCB LAYOUT
 (PCB TOLERANCE ±0.05)

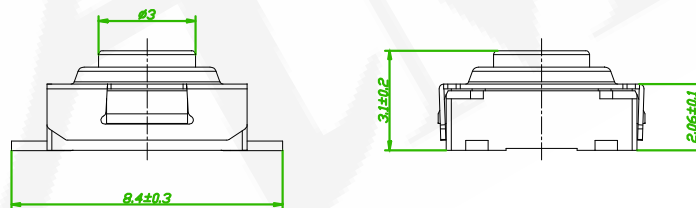

6STMS23-XXXXXXXXXA01

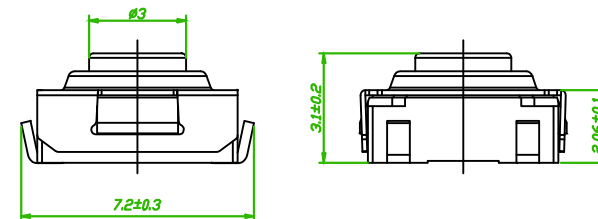

6STMS23-XXXXXXXXXA02

P/N	OPERATING FORCE
6STMS23-XXX160NXXA01	160gf±30gf
6STMS23-XXX250NXXA01	250gf±50gf
6STMS23-XXX160NXXA02	160gf±30gf
6STMS23-XXX250NXXA02	250gf±50gf
6STMS23-XXX400NXXA02	400gf±100gf

	REC2510000098	Oliver	2025/10/30
	REC2507000148	Willy	2025/07/31
	REC2507000111	Willy	2025/07/23
REV.	ECN NO. OR DESCRIPTION	REVISED	DATE

糧德精密有限公司
 Amtek Technology Co., Ltd.
 TEL: 886-2-2260-6878
 FAX: 886-2-2260-8030

品名 TITLE	TACT SWITCH SMT V/T TYPE			頁數 Page	1/1
品號 PART NO.	6STMS23-XXXXXXXXXA0X(1-2)		繪圖 DRAWN	JOHN 2025/06/16	
圖號 DRAWING NO.	GN162-JH413	版本 REV.	F	核對 CHECKED	JOSH 2025/06/16
客戶品號 CUSTOMER P/N		比例 SCALE	None	承認 APPROVED	JOSH 2025/06/16
公差 TOLERANCE	4<L≤16 ±0.3 L≤4 ±0.2	單位 UNIT	mm	THIRD ANGLE PROJECTION	