

SPECIFICATIONS

DIELECTRIC STRENGTH: AC250V /1MIN
 RATING:DC12V 50mA MAX,DC1V 10μA MIN
 CONTACT RESISTANCE:100mΩ MAX
 INSULATION RESISTANCE:100MΩ MIN
 OPERATING LIFE:3,000,000 CYCLES
 OPERATING FORCE:120gf±30gf OR 180gf±50gf OR 250gf±50gf
 350gf±70gf OR 400gf±100gf OR 500gf±100gf
 700gf±150gf

MATERIALS

BASE:NYLON6T
 TERMINAL:BRASS,SILVER PLATED
 CONTACT:STAINLESS STEEL,SILVER PLATED
 COVER:BRASS
 ACTUATOR:PPA

ORDER INFORMATION

6 S T M S 1 9 - X X X X X X X X X X A 0 1

026:H=2.6mm	120:120gf±30gf	400:400gf±100gf	W:NATURAL	N:W/O PEG W/O GROUND WITH SHELL	H:T/R W/O GAP
035:H=3.5mm	180:180gf±50gf	500:500gf±100gf	U:BLUE		
043:H=4.3mm	250:250gf±50gf	700:700gf±150gf	R:RED		
049:H=4.9mm	350:350gf±70gf		O:ORANGE		
052:H=5.2mm					

P/N	STEM COLOR
6STMS19-035XXXWXXA01	NATURAL
6STMS19-043XXXWXXA01	
6STMS19-049XXXWXXA01	
6STMS19-052XXXWXXA01	BLUE
6STMS19-026XXXUXXA01	
6STMS19-035XXXUXXA01	
6STMS19-052XXXUXXA01	RED
6STMS19-035XXXRXXA01	
6STMS19-052XXXRXXA01	ORANGE
6STMS19-035XXXOXXA01	
6STMS19-052XXXOXXA01	

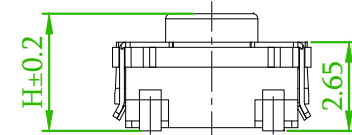
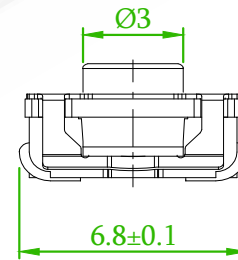
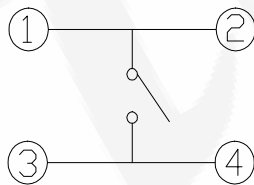
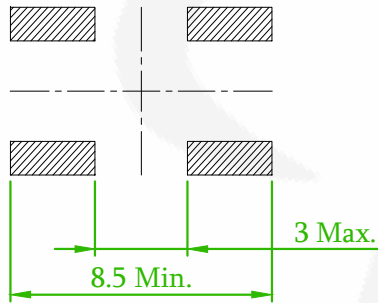
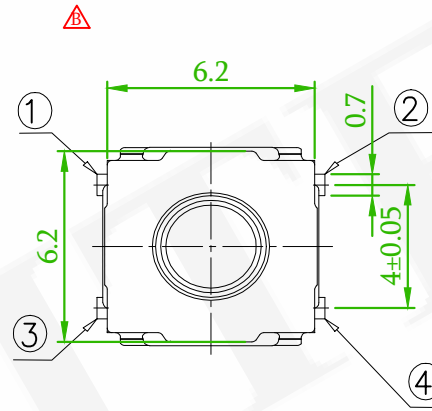
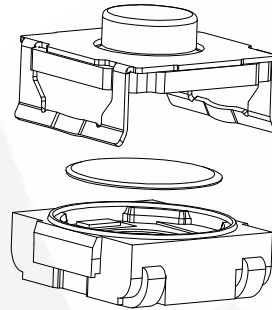

RECOMMENDED PCB LAYOUT
(PCB TOLERANCE ±0.05)

CIRCUIT DIAGRAM

REV.	ECN NO. OR DESCRIPTION	REVISED	DATE
	REC2510000103	Oliver	2025/11/03
	REC2507000041	Willy	2025/07/08
	BPM 20250613001	Willy	2025/06/30

 糧德精密有限公司 Amtek Technology Co., Ltd. TEL: 886-2-2260-6878 FAX: 886-2-2260-8030	品名 TITLE	TACT SWITCH SMT V/T TYPE				頁數 Page	1/1
	品號 PART NO.	6STMS19-XXXXXXXXXA01			繪圖 DRAWN	JOHN 2025/06/16	
	圖號 DRAWING NO.	GN162-JH409	版本 REV.	D	核對 CHECKED	JOSH 2025/06/16	
	客戶品號 CUSTOMER P/N		比例 SCALE	None	承認 APPROVED	JOSH 2025/06/16	
	公差 TOLERANCE	±0.30	單位 UNIT	mm	THIRD ANGLE PROJECTION		