

SPECIFICATIONS

DIELECTRIC STRENGTH: AC250V /1MIN
 RATING:DC12V,50mA MAX
 CONTACT RESISTANCE:100mΩ MAX
 INSULATION RESISTANCE:100MΩ MIN
 OPERATING LIFE:100,000 CYCLES
 OPERATING FORCE:130gf±30gf OR 180gf±50gf
 250gf±50gf OR 320gf±70gf

MATERIALS

BASE:NYLON6T
 TERMINAL:BRASS,SILVER PLATED
 CONTACT:STAINLESS STEEL,SILVER PLATED
 COVER:STAINLESS STEEL
 ACTUATOR:NYLON6T

ORDER INFORMATION

6 S T M S 1 2 - X X X X X X X X A 0 1

043: DIM H=4.3mm	130: 130gf±30gf	B: BLACK	N: W/O PEG W/O GROUND WITH SHELL	H: T/R W/O CAP
050: DIM H=5.0mm	180: 180gf±50gf			
	250: 250gf±50gf			
	320: 320gf±70gf			



TABLE

P/N	H
6STMS12-043XXXBXXA01	4.3mm
6STMS12-050XXXBXXA01	5.0mm

CIRCUIT DIAGRAM

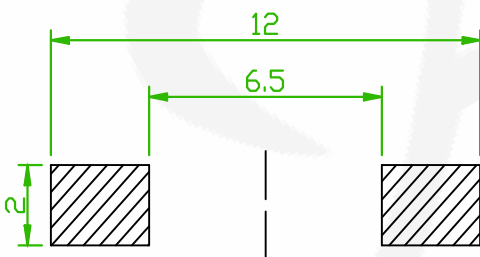
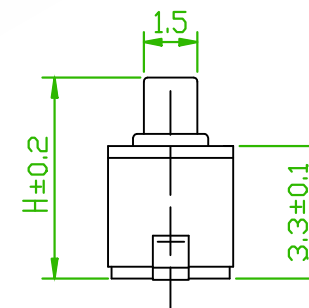
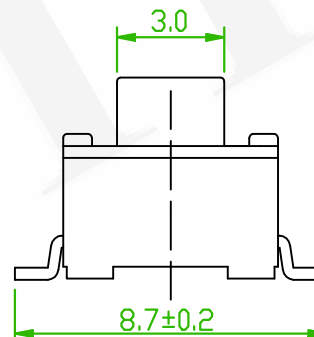
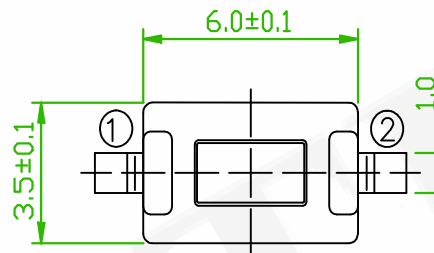
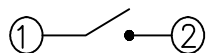

RECOMMENDED PCB LAYOUT
 (PCB TOLERANCE ±0.05)

	REC251000093	Oliver	2025/10/30
	REC250700037	Willy	2025/07/08
	BPM 20250613001	John	2025/06/27
REV.	ECN NO. OR DESCRIPTION	REVISED	DATE

糧德精密有限公司
 Amtek Technology Co., Ltd.
 TEL: 886-2-2260-6878
 FAX: 886-2-2260-8030

品名 TITLE	TACT SWITCH SMT V/T TYPE				頁數 Page	1/1
品號 PART NO.	6STMS12-XXXXXXXXA01			繪圖 DRAWN	JOHN 2025/06/13	
圖號 DRAWING NO.	GN162-JH402	版本 REV.	D	核對 CHECKED	JOSH 2025/06/13	
客戶品號 CUSTOMER P/N		比例 SCALE	None	承認 APPROVED	JOSH 2025/06/13	
公差 TOLERANCE	16<X≤63 ±0.4	4<X≤16 ±0.3	X≤4 ±0.2	單位 UNIT	mm	THIRD ANGLE PROJECTION