



ORDER INFORMATION

SPECIFICATIONS 
 DIELECTRIC STRENGTH: AC250V 50Hz/1MIN
 RATING:DC12V,50mA MAX
 CONTACT RESISTANCE:50mΩ MAX
 INSULATION RESISTANCE:100MΩ MIN
 OPERATING LIFE:10,000 CYCLES
 OPERATING FORCE:200gf±50gf
 TRAVEL:2.0±0.1mm
 OPERATING TEMPERATURE:-40°C~+85°C 

6 S S D R 0 1 - X X X X X X X X X F 0 1



MATERIALS
 BASE:LCP,BLACK
 TERMINAL:BRASS,SILVER PLATED
 CONTACT:BERYLLIUM COPPER,SILVER PLATED
 COVER: STAINLESS STEEL
 ACTUATOR:PPA

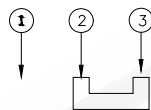

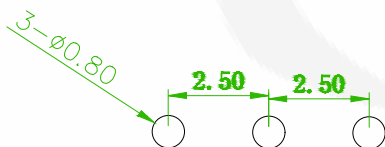

CIRCUIT DIAGRAM

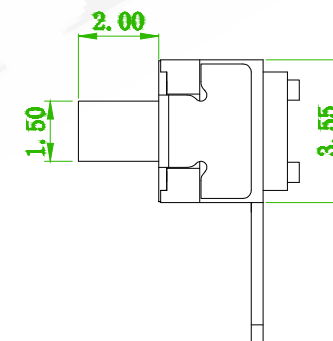
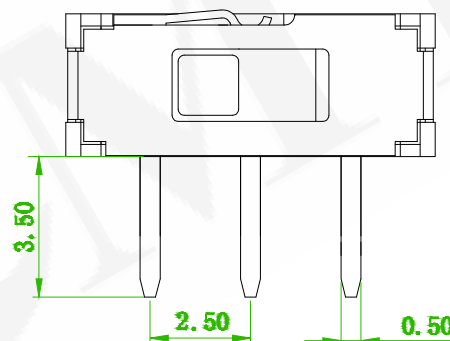
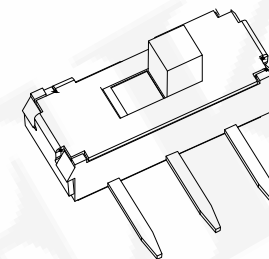
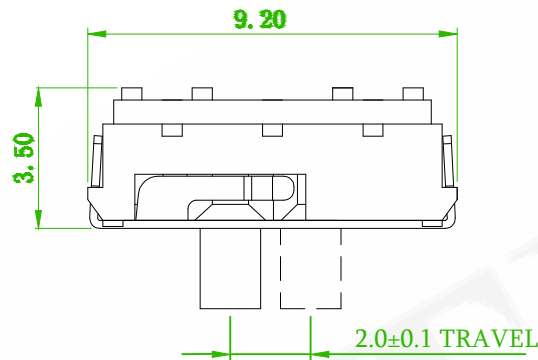

RECOMMENDED PCB LAYOUT
 (PCB TOLERANCE ±0.05)



	ECN-202603009 Revise the drawing	Gaby	2026/03/12
	RECN2511000012 Revise the drawing	Oliver	2025/11/04
	RECN2507000068 Revise the drawing	Willy	2025/07/11
REV.	ECN NO. OR DESCRIPTION	REVISED	DATE



懋德精密有限公司
Amtek Technology Co., Ltd.
TEL: 886-2-2260-6878
FAX: 886-2-2260-8030

品名 TITLE	SLIDE SWITCH DIP R/A TYPE				頁數 Page	1/1
品號 PART NO.	6SSDR01-XXXXXXXXXXF01			繪圖 DRAWN	John 2025/06/10	
圖號 DRAWING NO.	GN219-JH353	版本 REV.	D	核對 CHECKED	Josh 2025/06/10	
客戶品號 CUSTOMER P/N		比例 SCALE	None	承認 APPROVED	Josh 2025/06/10	
公差 TOLERANCE	.X ± 0.15 .XX ± 0.1	單位 UNIT	mm	THIRD ANGLE PROJECTION		