

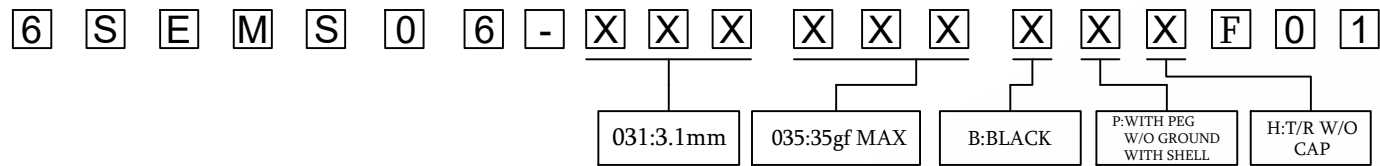

SPECIFICATIONS 
 DIELECTRIC STRENGTH: AC100V/1MIN
 RATING: DC 5V 1mA MAX
 CONTACT RESISTANCE: 3Ω MAX
 INSULATION RESISTANCE: 500MΩ MIN
 OPERATING LIFE: 50,000 CYCLES
 OPERATING FORCE: 35gf MAX
 TRAVEL: 1.93±0.5mm
 OPERATING TEMPERATURE: -40°C~+85°C

ORDER INFORMATION



MATERIALS
 BASE: PPA, BLACK
 TERMINAL: PHOSPHOR BRONZE, SILVER PLATED
 CONTACT: PHOSPHOR BRONZE, SILVER PLATED
 COVER: STAINLESS STEEL 
 ACTUATOR: PPA, BLACK
 SPRING: STAINLESS STEEL
 SLIDER: PPA, BLACK

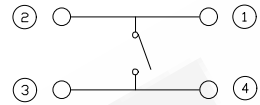



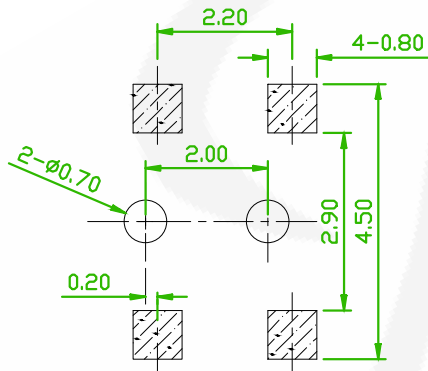
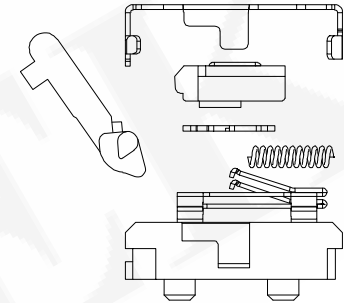
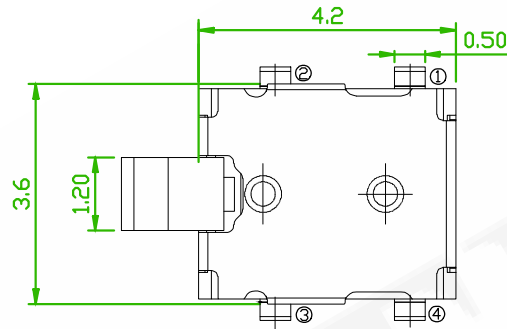

CIRCUIT DIAGRAM

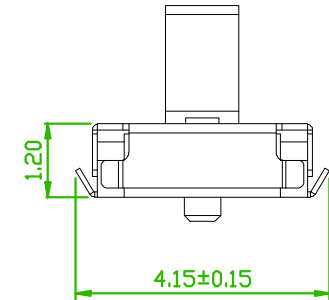
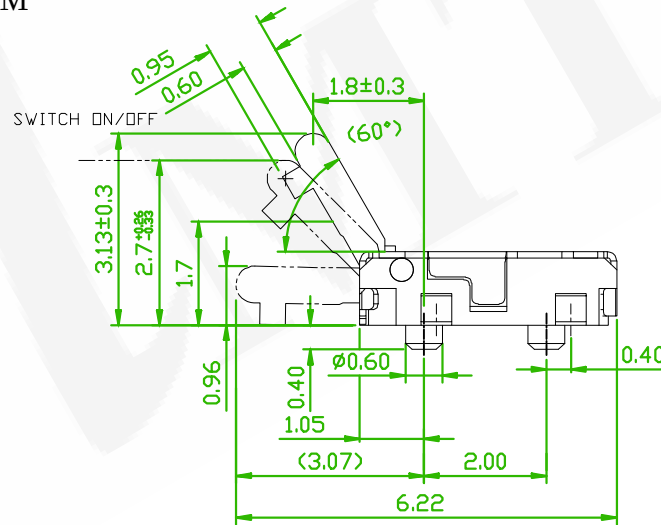

RECOMMENDED PCB LAYOUT
 (PCB TOLERANCE ±0.05)



	REC2511000017	Oliver	2025/11/05
	REC2507000045	Willy	2025/07/09
	REC2507000008	Willy	2025/07/03
REV.	ECN NO. OR DESCRIPTION	REVISED	DATE

 糧德精密有限公司 Amtek Technology Co., Ltd. TEL: 886-2-2260-6878 FAX: 886-2-2260-8030	品名 TITLE	DETECTOR SWITCH SMT V/T TYPE			頁數 Page	1/1
	品號 PART NO.	6SEMS06-XXXXXXXXF01			繪圖 DRAWN	JOHN 2025/06/12
	圖號 DRAWING NO.	GN219-JH383	版本 REV.	D	核對 CHECKED	JOSH 2025/06/12
	客戶品號 CUSTOMER P/N		比例 SCALE	None	承認 APPROVED	JOSH 2025/06/12
	公差 TOLERANCE	.X ± 0.1 .XX ± 0.05	單位 UNIT	mm	THIRD ANGLE PROJECTION	