

**SPECIFICATIONS** 

DIELECTRIC STRENGTH: AC100V 50Hz/1MIN  
 RATING:DC3V,10mA MAX  
 CONTACT RESISTANCE:500mΩ MAX  
 INSULATION RESISTANCE:50MΩ MIN  
 OPERATING LIFE:50,000 CYCLES  
 OPERATING FORCE:30gf±15gf

**ORDER INFORMATION**

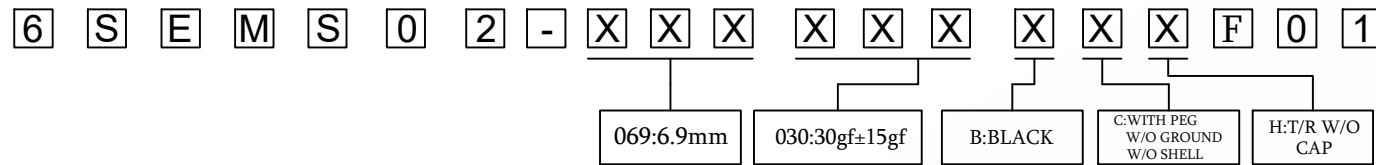



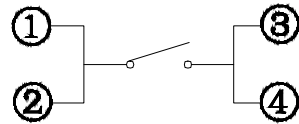

**MATERIALS**

BASE:NYLON 46,BLACK  
 TERMINAL:BRASS,SILVER PLATED  
 CONTACT:PHOSPHOR BRONZE,SILVER PLATED  
 COVER:NYLON 46,BLACK  
 ACTUATOR:NYLON 46,BLACK

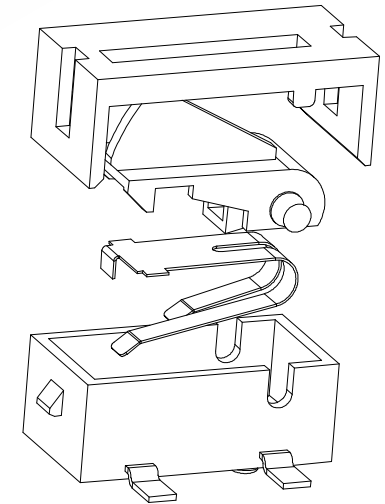
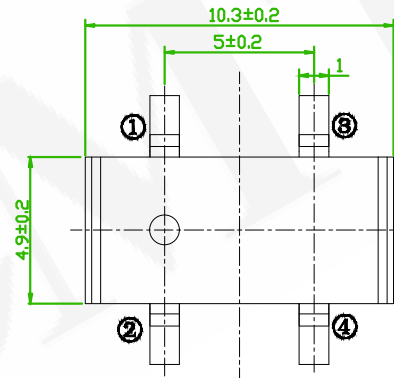
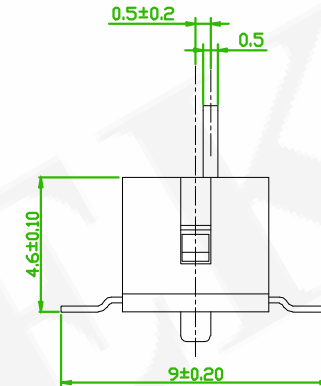
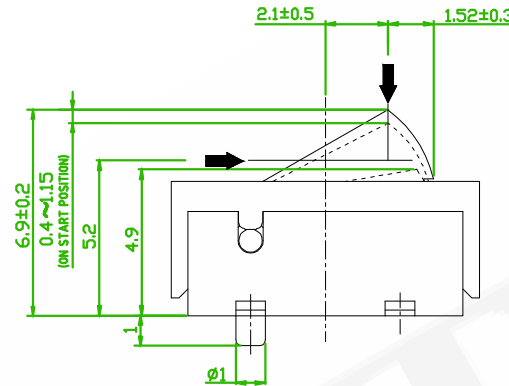
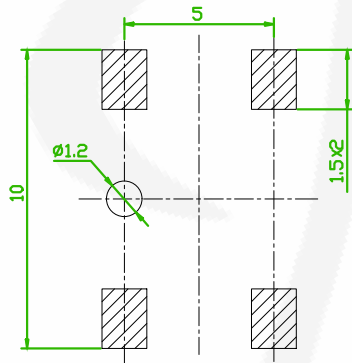

CIRCUIT DIAGRAM



	REC2511000017	Oliver	2025/11/05
	REC2507000067	Willy	2025/07/11
	BPM 20250307003	John	2025/05/27
REV.	ECN NO. OR DESCRIPTION	REVISED	DATE



**糧德精密有限公司**  
 Amtek Technology Co., Ltd.  
 TEL: 886-2-2260-6878  
 FAX: 886-2-2260-8030

品名 TITLE	DETECTOR SWITCH SMT V/T TYPE			頁數 Page	1/1
品號 PART NO.	6SEMS02-XXXXXXXXF01			繪圖 DRAWN	JOHN 2025/06/11
圖號 DRAWING NO.	GN219-JH370	版本 REV.	C	核對 CHECKED	JOSH 2025/06/11
客戶品號 CUSTOMER P/N		比例 SCALE	None	承認 APPROVED	JOSH 2025/06/11
公差 TOLERANCE	.X ± 0.1	單位 UNIT	mm	THIRD ANGLE PROJECTION	
	.XX ± 0.05				