

SPECIFICATIONS 

DIELECTRIC STRENGTH: AC100V 50Hz/1MIN
 RATING:DC3V,10mA MAX
 CONTACT RESISTANCE:500mΩ MAX
 INSULATION RESISTANCE:50MΩ MIN
 OPERATING LIFE:50,000 CYCLES
 OPERATING FORCE:50gf±20gf

MATERIALS

BASE:NYLON 46,BLACK
 TERMINAL:BRASS,SILVER PLATED
 CONTACT:STAINLESS STEEL,SILVER PLATED
 COVER:NYLON 46,BLACK
 ACTUATOR:NYLON 46,BLACK
 SPRING:STAINLESS STEEL WIRE

ORDER INFORMATION

6 S E M S 0 1 - X X X X X X X X X F 0 1

065:6.5mm 050:50gf±20gf B:BLACK C:WITH PEG W/O GROUND W/O SHELL H:T/R W/O CAP

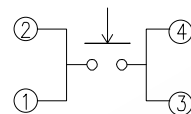

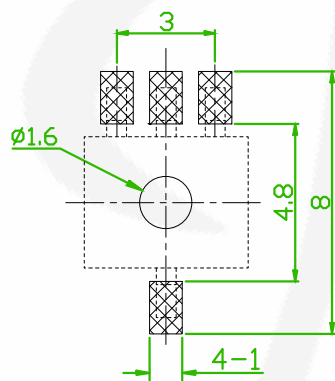
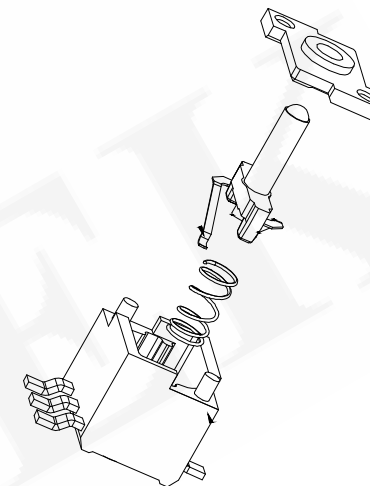
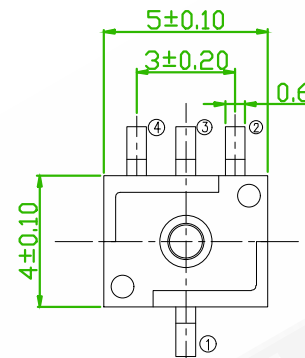

CIRCUIT DIAGRAM

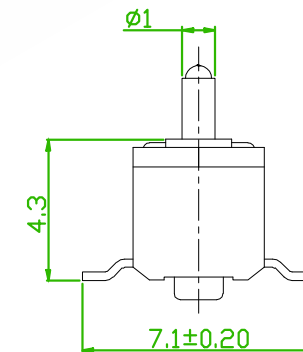
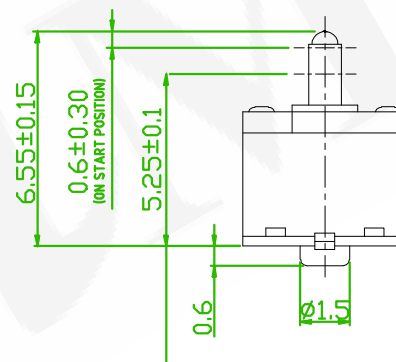

RECOMMENDED PCB LAYOUT
 (PCB TOLERANCE ±0.05)



	REC2511000017	Oliver	2025/11/05
	REC2507000068	Willy	2025/07/11
	BPM 20250307003	John	2025/05/27
REV.	ECN NO. OR DESCRIPTION	REVISED	DATE



韋德精密有限公司
 Amtek Technology Co., Ltd.
 TEL: 886-2-2260-6878
 FAX: 886-2-2260-8030

品名 TITLE	DETECTOR SWITCH SMT V/T TYPE			頁數 Page	1/1
品號 PART NO.	6SEMS01-XXXXXXXXXF01		繪圖 DRAWN	JOHN 2025/06/11	
圖號 DRAWING NO.	GN219-JH369	版本 REV.	C	核對 CHECKED	JOSH 2025/06/11
客戶品號 CUSTOMER P/N		比例 SCALE	None	承認 APPROVED	JOSH 2025/06/11
公差 TOLERANCE	.X ± 0.1	單位 UNIT	mm	THIRD ANGLE PROJECTION	
	.XX ± 0.05				