

ORDER INFORMATION

5 H S P C 0 2 - 1 6 X X X X X X - 0 1

SPECIFICATION

OPERATION TEMPERATURE: -40 °C TO +85 °C

MATERIAL

CAGE: COPPER ALLOY

EMI SPRING :COPPER ALLOY

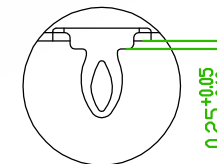
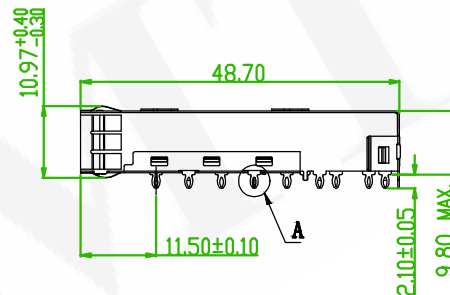
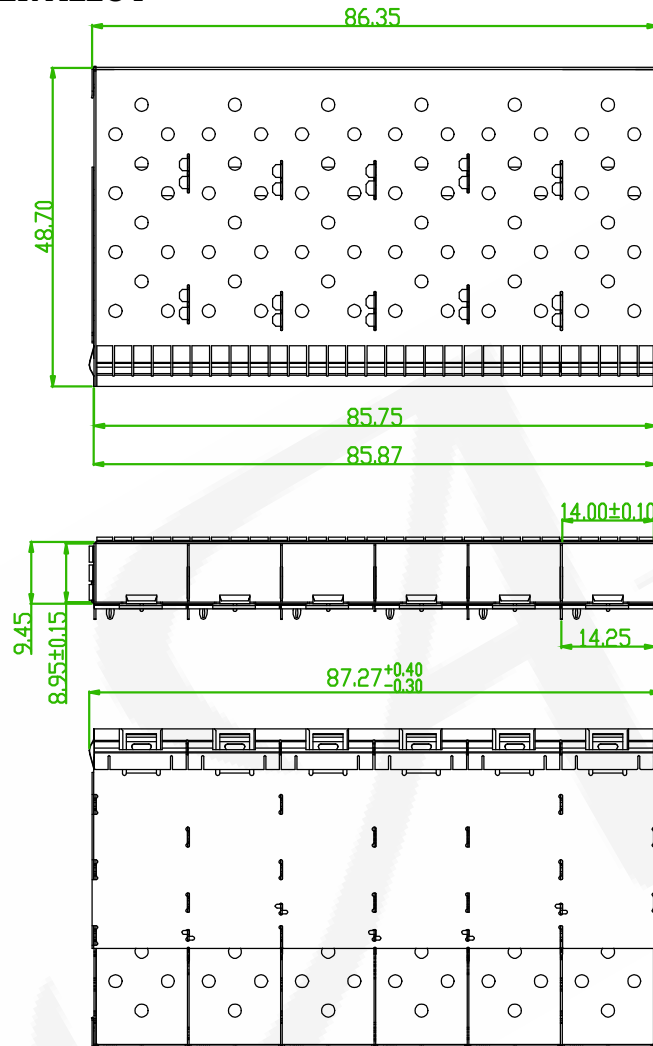

Detail A

懌德精密有限公司
Amtek Technology Co., Ltd.
TEL: 886-2-2260-6878
FAX: 886-2-2260-8030

品名 TITLE	SFP+ CAGE			頁數 Page	1/3
品號 PART NO.	5HSPC02-16XXXXXX-01			繪圖 DRAWN	Nick 2019/06/18
圖號 DRAWING NO.	GN189-NI263	版本 REV.	B	核對 CHECKED	Josh 2019/06/18
客戶品號 CUSTOMER P/N		比例 SCALE	None	承認 APPROVED	Josh 2019/06/18
公差 TOLERANCE	.X ± 0.25 .XX ± 0.20	單位 UNIT	mm	THIRD ANGLE PROJECTION	

REV.	ECN-202602039	Roland	2026/04/09
	ECN NO. OR DESCRIPTION	REVISED	DATE

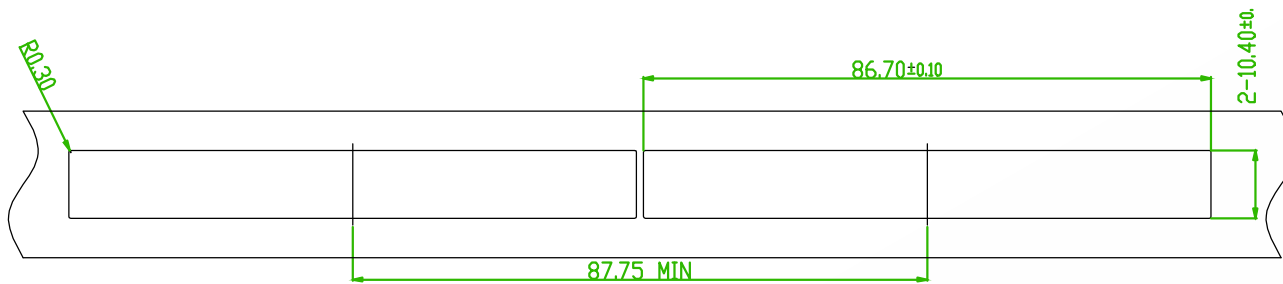

RECOMMENDED BEZEL CUT-OUT SINGLE SIDED APPLICATIONS

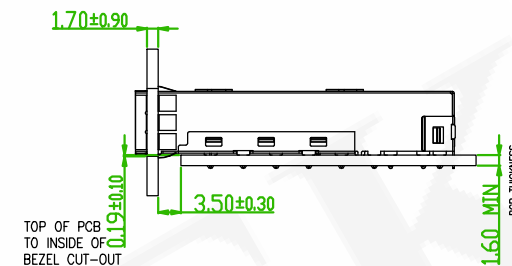

MOUNTED ON PC BOARD
SHOWN THRU RECOMMENDED BEZEL

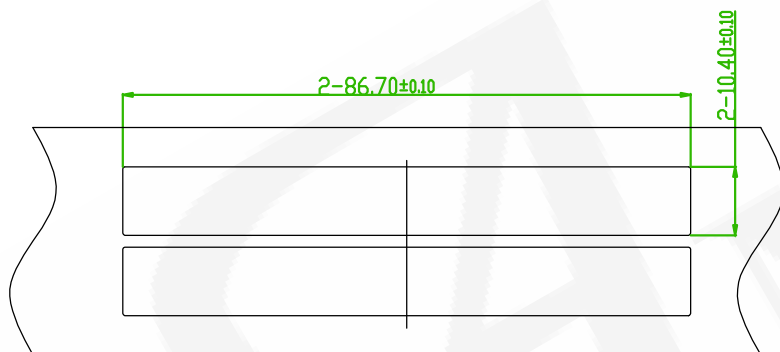

RECOMMENDED BEZEL CUT-OUT BELLY TO BELLY APPLICATIONS

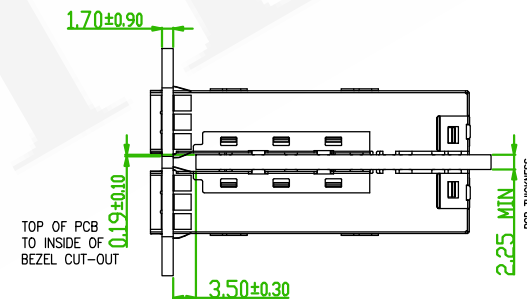

MOUNTED BELLY TO BELLY ON PC BOARD
SHOWN THRU RECOMMENDED BEZEL

REV.	ECN-202602039	Roland	2026/04/09
	ECN NO. OR DESCRIPTION	REVISED	DATE

糧德精密有限公司
Amtek Technology Co., Ltd.
TEL: 886-2-2260-6878
FAX: 886-2-2260-8030

品名 TITLE	SFP+ CAGE			頁數 Page	2/3
品號 PART NO.	5HSPC02-16XXXXXX-01		繪圖 DRAWN	Nick 2019/06/18	
圖號 DRAWING NO.	GN189-NI263	版本 REV.	B	核對 CHECKED	Josh 2019/06/18
客戶品號 CUSTOMER P/N		比例 SCALE	None	承認 APPROVED	Josh 2019/06/18
公差 TOLERANCE	.X ± 0.25 .XX ± 0.20	單位 UNIT	mm	第三 ANGLE PROJECTION	

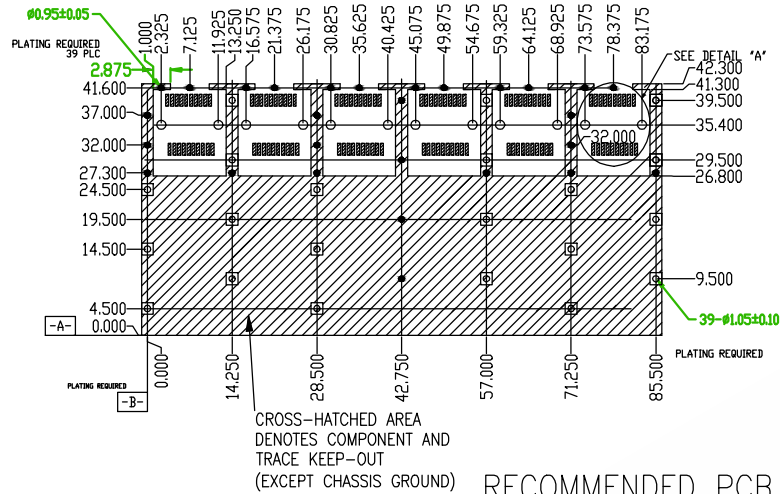

CROSS-HATCHED AREA DENOTES COMPONENT AND TRACE KEEP-OUT (EXCEPT CHASSIS GROUND)

RECOMMENDED PCB CONFIGURATION WITH KEEP-OUT AREAS SINGLE SIDED APPLICATIONS

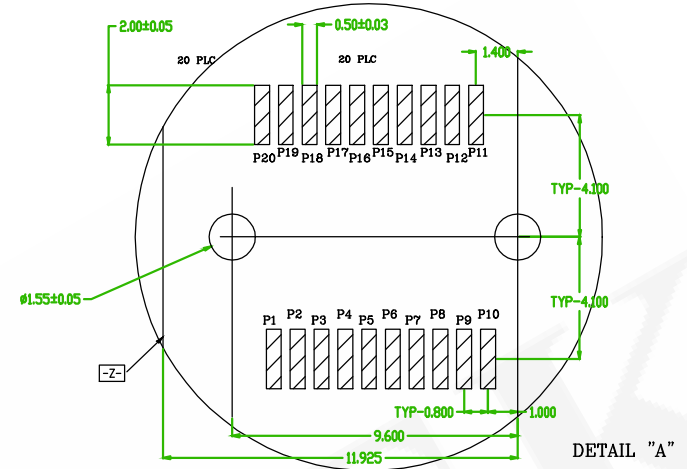

DETAIL "A"

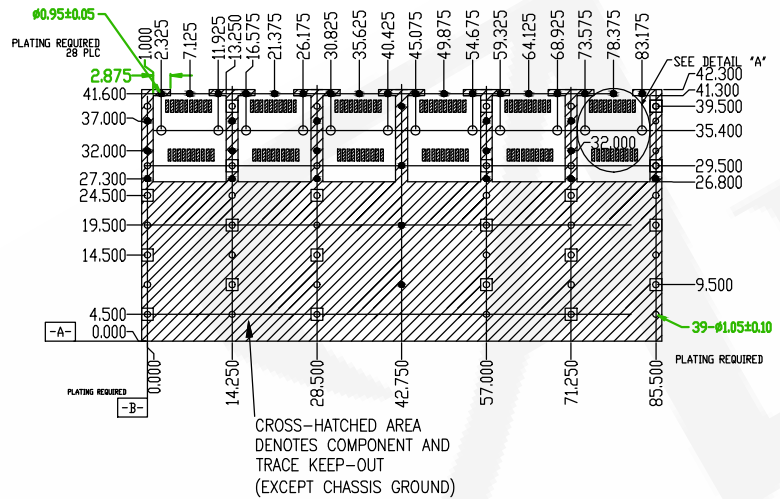

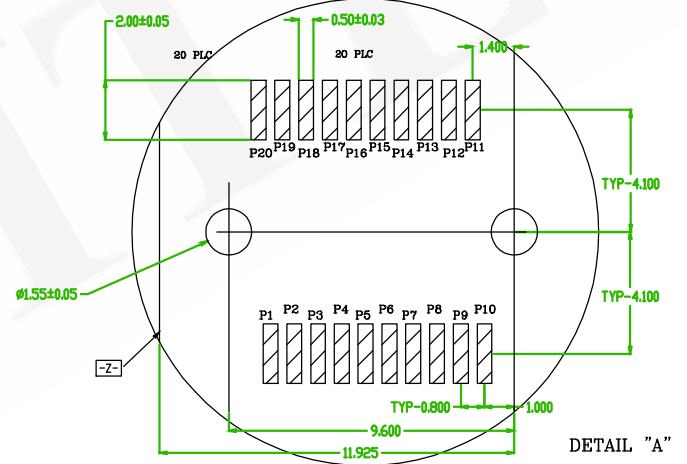

CROSS-HATCHED AREA DENOTES COMPONENT AND TRACE KEEP-OUT (EXCEPT CHASSIS GROUND)

RECOMMENDED PCB CONFIGURATION WITH KEEP-OUT AREAS PFLY TO PFLY APPLICATIONS



DETAIL "A"

REV.	ECN-202602039	Roland	2026/04/09
	ECN NO. OR DESCRIPTION	REVISED	DATE

 糧德精密有限公司 Amtek Technology Co., Ltd. TEL: 886-2-2260-6878 FAX: 886-2-2260-8030	品名 TITLE	SFP+ CAGE			頁數 Page	3/3
	品號 PART NO.	5HSPC02-16XXXXXX-01			繪圖 DRAWN	Nick 2019/06/18
	圖號 DRAWING NO.	GN189-NI263	版本 REV.	B	核對 CHECKED	Josh 2019/06/18
	客戶品號 CUSTOMER P/N		比例 SCALE	None	承認 APPROVED	Josh 2019/06/18
	公差 TOLERANCE	.X ± 0.25	單位 UNIT	mm	THIRD ANGLE PROJECTION	
		.XX ± 0.20				