

SPECIFICATION

Current Rating: 2 AMP
 Voltage Rating: 500V
 Insulation Resistance: 500MΩ Min.
 Contact Resistance: 30mΩ Max.
 Operation Temperature: -55°C to +85°C

MATERIAL

Insulator: PBT+30%G.F, UL94V-0
 Contact Pin: Phosphor Bronze

ORDER INFORMATION

5 S B D 1 2 2 0 D 0 - T 0 B L B - B 0 2

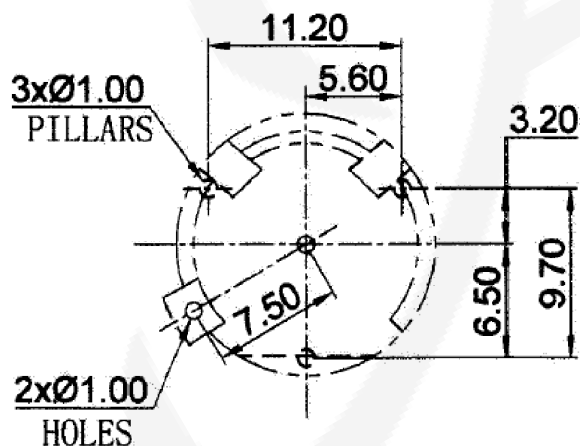
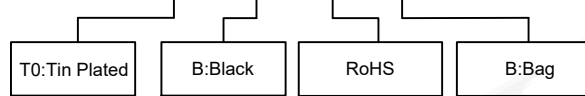

PCB MOUNTING LAYOUT

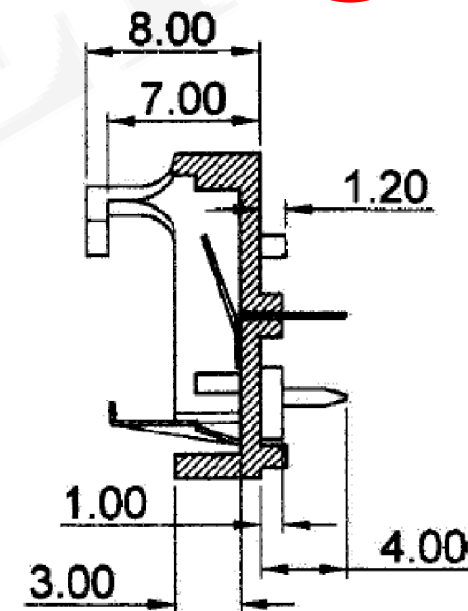
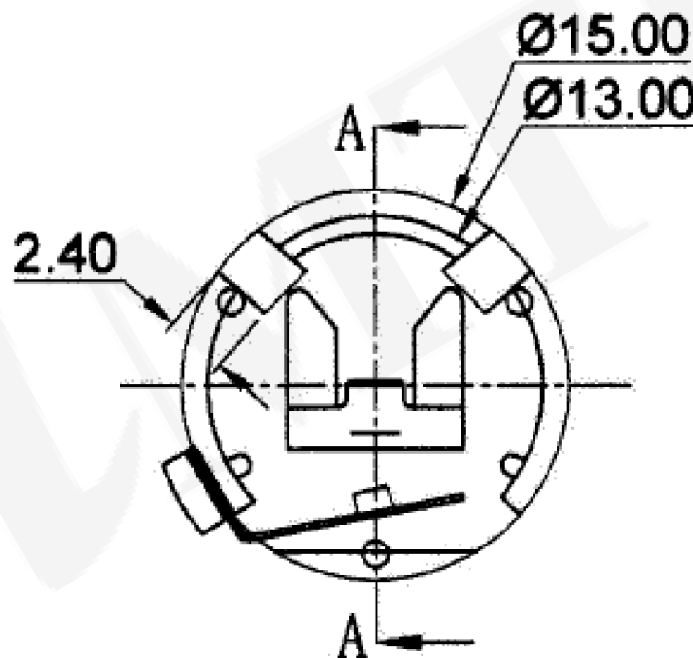

SECTION A-A

| | | | | | | | |
|---|----------------------|-------------------------|-------------|-------------|---------------------|------------------------------|--|
|  糧德精密有限公司 Amtek Technology Co., Ltd. TEL: 886-2-2260-6878 FAX: 886-2-2260-8030 | 品名 TITLE | BATTERY HOLDER | | | 頁數 Page | 1/1 | |
| | 品號 PART NO. | 5SBD1220D0-T0BLB-B02 | | 繪圖 DRAWN | Alice 2021/06/15 | | |
| | 圖號 DRAWING NO. | GW093-AZ249 | 版本 REV. | A | 核對 CHECKED | Josh 2021/06/15 | |
| | 客戶品號 CUSTOMER P/N | | 比例 SCALE | None | 承認 APPROVED | Josh 2021/06/15 | |
| | 公差 TOLERANCE | .X ± 0.30 .XX ± 0.20 | .X°±3 | 單位 UNIT | mm | THIRD ANGLE PROJECTION | |

| | | | |
|------|------------------------|---------|------|
| REV. | ECN NO. OR DESCRIPTION | REVISED | DATE |
| | | | |