

**ELECTRICAL**

Standard: UL IEC  
 Rated Voltage: 300V 300V  
 Rated Current: 15A 10A  
 Contact Resinistance: 20MΩ  
 Insulation Resistance: 500MΩ/DC 1000V  
 Wire Range: 30-14AWG 2.5mm<sup>2</sup>  
 Withstanding Voltage: AC 1600V for one minute

**MECHANICAL**

Torque: 0.4Nm(3.61Lb'in)  
 Strip Length: 6~7mm  
 Temp. Range: -40°C ~ +105°C

**MATERIAL**

Housing: PA66, UL94V-0  
 Screws: M2.5, Steel, Zinc Plated  
 Pin Header: Brass, Tin Plated  
 Clamp: Brass, Ni Plated

**DIMENSIONS**

Pitch: 5.0mm  
 Poles: 2P-24P

**ORDER INFORMATION**

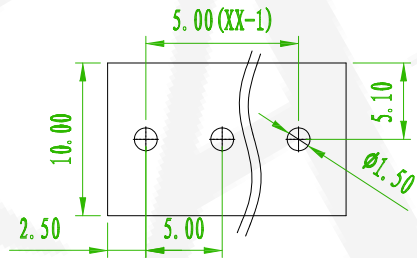
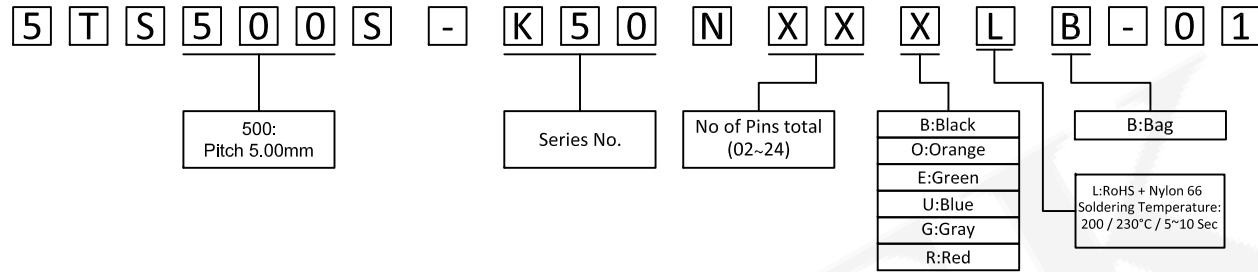

P.C.B. LAYOUT

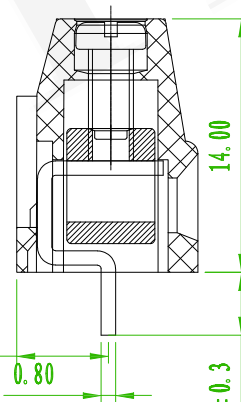
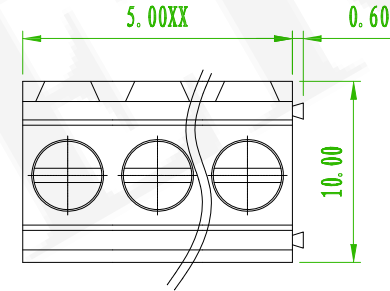

SECTION A-A

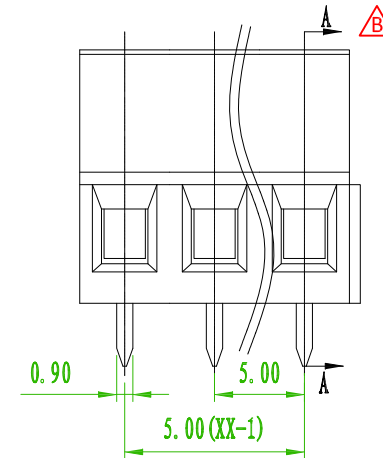

linear dimension (Tolerances Standard GB/T 14486-2008)										
variable range	to 6	over 6 to 10	over 10 to 30	over 30 to 60	over 60 to 100	over 100 to 160	over 160 to 10	over 10 to 100	over 100 to 1000	
tolerance	±0.20	±0.30	±0.50	±0.70	±1.00	±1.30	±1.60	0.10	0.30	0.60

REV.	QEC 190913: Revise the dimension、List、SPEC、Drawing	Nick	2019/10/14
	ECN NO. OR DESCRIPTION	REVISED	DATE

糧德精密有限公司  
 Amtek Technology Co., Ltd.  
 TEL: 886-2-2260-6878  
 FAX: 886-2-2260-8030

品名 TITLE	Terminal Block				頁數 Page	1/1
品號 PART NO.	5TS500S-K50NXXLB-01			繪圖 DRAWN	Mia 2016/10/24	
圖號 DRAWING NO.	GN011-NI434	版本 REV.	B	核對 CHECKED	Jonny 2016/10/24	
客戶品號 CUSTOMER P/N		比例 SCALE	None	承認 APPROVED	Aaron 2016/10/24	
公差 TOLERANCE		單位 UNIT	mm	THIRD ANGLE PROJECTION		

Old Part No. :TB500-5.0-XXP-1X-00A-L