

ORDER INFORMATION

Electrical

Standard: UL IEC
 Rated Voltage: 300V 450V
 Rated Current: 15A 17.5A
 Contact Resistance: 20mΩ
 Insulation Resistance: 500MΩ / DC 500V
 Withstanding Voltage: AC 2000V for one minute

5 T P 7 6 2 R - 2 E G N X X E L B - 0 1

762:
Pitch 7.62mm

Series No.

No of Pins total
(02~24)

E:Green

B:Bag



Mechanical

Temp. Range: -40°C~+105°C
 Max Soldering: +250°C for 5 Sec

Dimensions

Pitch: 7.62mm
 Poles: 2-24P

Material

Housing: Nylon66, UL94V-0
 Pin header: Brass, Tin plated

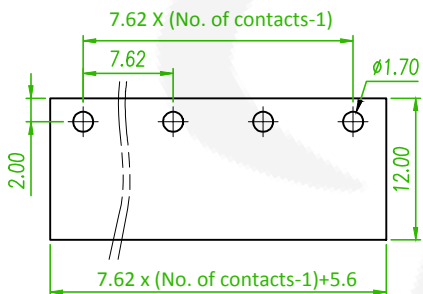

P.C.B. LAYOUT

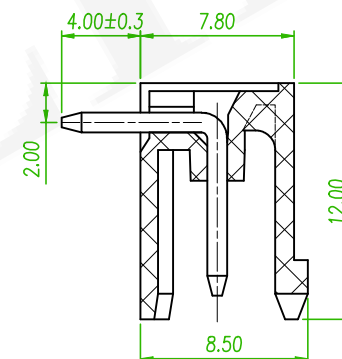
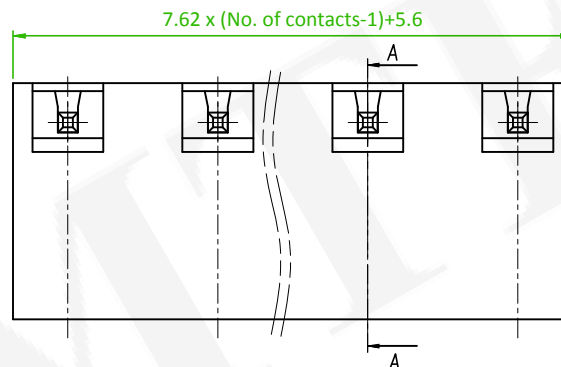

SECTION:A-A

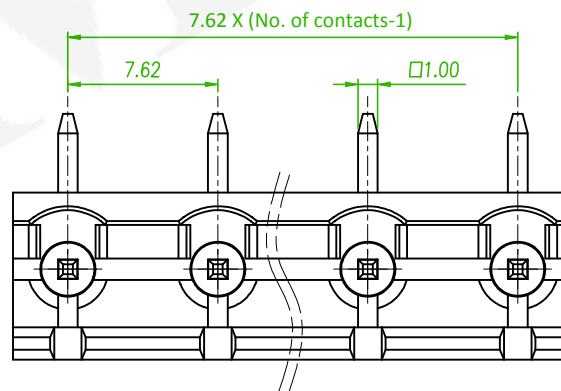

Old Part No. :TB2ER-7.62-XXP-1X-00A-L

linear dimension (Tolerances Standard GB/T 14486-2008)



variable range	to 6	over 6 to 10	over 10 to 30	over 30 to 60	over 60 to 100	over 100 to 160	over 160 to	to 10	over 10 to 100	over 100 to
tolerance	±0.20	±0.30	±0.50	±0.70	±1.00	±1.30	±1.60	0.10	0.30	0.60

REV.	ECN NO. OR DESCRIPTION	REVISED	DATE
△x1	ECN NO:200718 Revise the Tolerance	Alice	2020/09/30

糧德精密有限公司
 Amtek Technology Co., Ltd.
 TEL: 886-2-2260-6878
 FAX: 886-2-2260-8030

品名 TITLE	Terminal Block				頁數 Page	1/1
品號 PART NO.	5TP762R-2EGNXXELB-01			繪圖 DRAWN	Mia 2016/08/18	
圖號 DRAWING NO.	GN011-AL348	版本 REV.	B	核對 CHECKED	Boris 2016/08/18	
客戶品號 CUSTOMER P/N		比例 SCALE	None	承認 APPROVED	Boris 2016/08/18	
公差 TOLERANCE		單位 UNIT	mm	THIRD ANGLE PROJECTION		