

**ELECTRICAL**

Standard: UL IEC  
 Rated Voltage: 300V 450V  
 Rated Current: 15A 17.5A  
 Contact Resistance: 20mΩ  
 Withstanding Voltage: AC 2000V for one min  
 Insulation Resistance: 500MΩ  
 Wire range: 28-14AWG 1.5mm<sup>2</sup>

**ORDER INFORMATION**

5 T P 7 5 0 N - 2 K A E X X E L X - 0 1

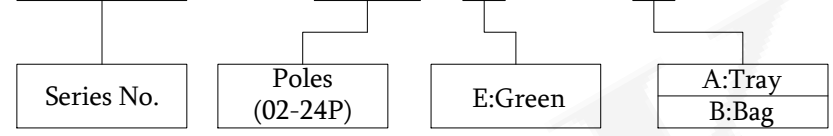

**MECHANICAL**

Temp. Range: -40°C ~ +105°C  
 Torque: 0.5Nm  
 Steip length: 7-8mm

**MATERIAL**

Housing: PA66, UL94V-0  
 Screws: M3, Steel, Zn plated  
 Clamp: Phosphor bronze, Ni plated  
 Cage: Brass, Ni plated  
 Fixing screws: M2.5 Steel Zn plated

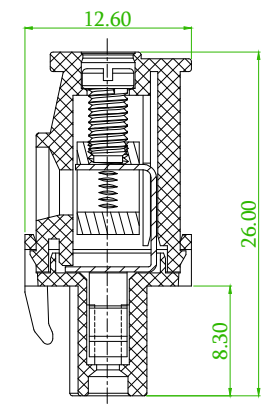
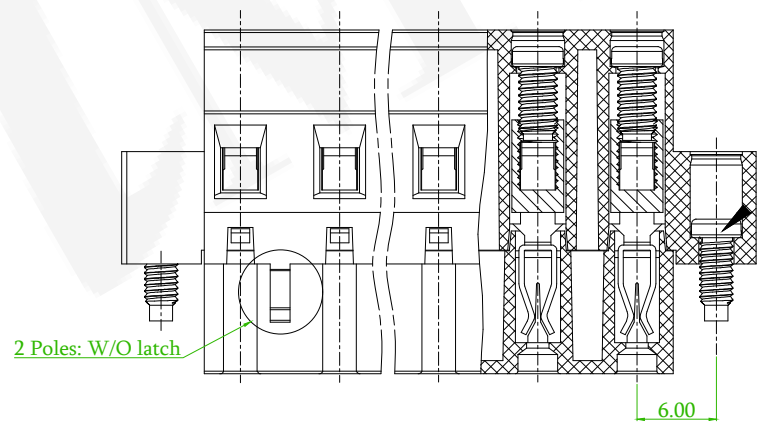
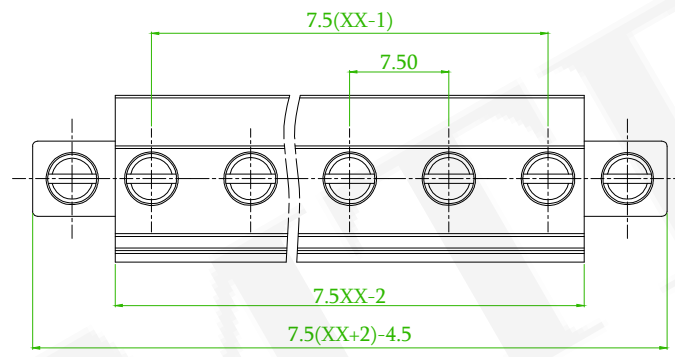

linear dimension(Tolerances Standard GB/T 14486-2008)								—	∕	⊥
variable range	to 6	over 6 to 10	over 10 to 30	over 30 to 60	over 60 to 100	over 100 to 160	over 160 to 10	over 10 to 100	over 100 to 100	
tolerance	±0.20	±0.30	±0.50	±0.70	±1.00	±1.30	±1.60	0.10	0.30	0.60

REV.	ECN NO. OR DESCRIPTION	REVISED	DATE
△Bx1	ECN NO:200718 Revise the Tolerance	Alice	2020/09/24

**禮德精密有限公司**  
 Amtek Technology Co., Ltd.  
 TEL: 886-2-2260-6878  
 FAX: 886-2-2260-8030

品名 TITLE	7.5mm Terminal Block			頁數 Page	1/1
品號 PART NO.	5TP750N-2KAEXXELX-01			繪圖 DRAWN	Eric 2018/11/30
圖號 DRAWING NO.	GN011-EA147	版本 REV.	B	核對 CHECKED	Josh 2018/11/30
客戶品號 CUSTOMER P/N		比例 SCALE	None	承認 APPROVED	Jason 2018/11/30
公差 TOLERANCE		單位 UNIT	mm	THIRD ANGLE PROJECTION	