

ORDER INFORMATION

ELECTRICAL

Standard: UL IEC
 Rated Voltage: 300V 450V
 Rated Current: 15A 17.5A
 Contact Resistance: 20mΩ
 Insulation Resistance: 500MΩ / DC 500V
 Withstanding Voltage: AC 2000V for one minute
 Wire range: 28~14AWG 1.5mm²

MECHANICAL

Torque: 0.5Nm (4.5Lb.in)
 Steip Length: 7-8mm
 Temp. Range: -40°C~+105°C
 MAX Soldering: +250°C, for 5 Sec

DIMENSIONS

Pitch: 5.08mm
 Poles: 2-24P

MATERIAL

Housing: Nylon66, UL94V-0
 Screws: M3, Steel, Zn plated
 Clamp: Phosphor bronze, Ni plated
 Cage: Brass, Ni plated

5 T P 5 0 8 N - 2 K A N X X X L X - 0 1

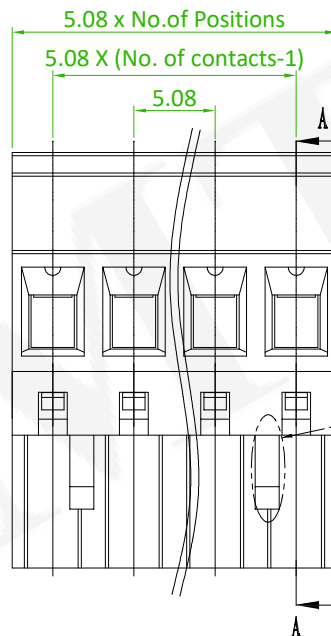
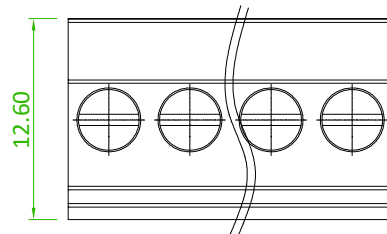
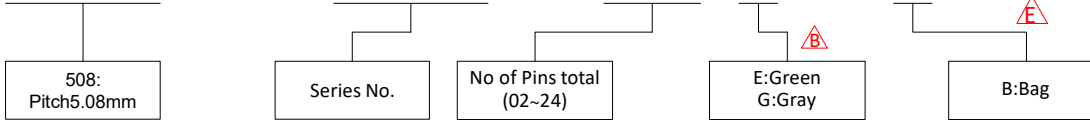

Only 2P with Latch

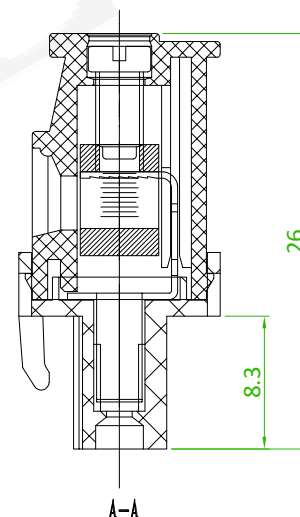

linear dimension (Tolerances Standard GB/T 14486-2008)



variable range	to 6	over 6 to 10	over 10 to 30	over 30 to 60	over 60 to 100	over 100 to 160	to 10	over 10 to 100	to 100	
tolerance	±0.20	±0.30	±0.50	±0.70	±1.00	±1.30	±1.60	0.10	0.30	0.60

Old Part No. : TB2EKA-5.08

△E	ECN NO.: 230714 Revise the PART NO	Benson	2023/08/29
△x2	ECN NO.: 201215 Revise the PART NO.	Alice	2020/12/30
△x1	ECN NO.: 200718 Revise the Tolerance	Alice	2020/09/18
REV.	ECN NO. OR DESCRIPTION	REVISED	DATE



糧德精密有限公司
 Amtek Technology Co., Ltd.
 TEL: 886-2-2260-6878
 FAX: 886-2-2260-8030

品名 TITLE	Terminal Block				頁數 Page	1/1
品號 PART NO.	△ 5TP508N-2KANXXXLX-01 △			繪圖 DRAWN	Mia 2016/08/23	
圖號 DRAWING NO.	GN011-MC521	版本 REV.	E	核對 CHECKED	Jonny 2016/08/23	
客戶品號 CUSTOMER P/N		比例 SCALE	None	承認 APPROVED	Aaron 2016/08/23	
公差 TOLERANCE		單位 UNIT	mm	THIRD ANGLE PROJECTION	