

**ELECTRICAL**

Standard: UL IEC  
 Rated Voltage: 300V 450V  
 Rated Current: 10A 20A  
 Contact Resistance: 20mΩ  
 Withstanding Voltage: AC 2000V for one min  
 Insulation Resistance: 500MΩ  
 Wire range: 26-12AWG 2.5mm<sup>2</sup>

**MECHANICAL**

Temp. Range: -40°C ~ +105°C  
 Steip length: 7-8mm

**MATERIAL**

Housing: PA66, UL94V-0  
 Clamp: Copper alloy, Sn plated  
 Wire guard: Stainless steel  
 Screws: Steel, Zn plated

**ORDER INFORMATION**

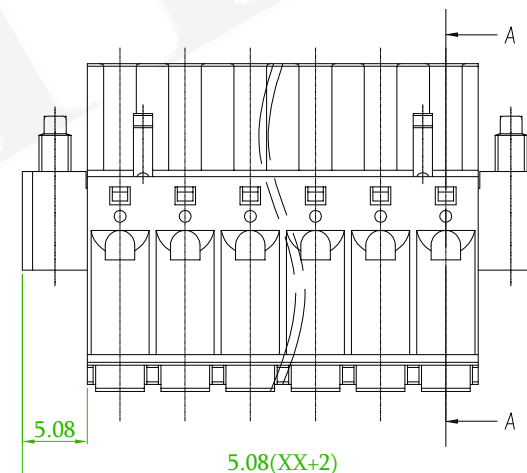
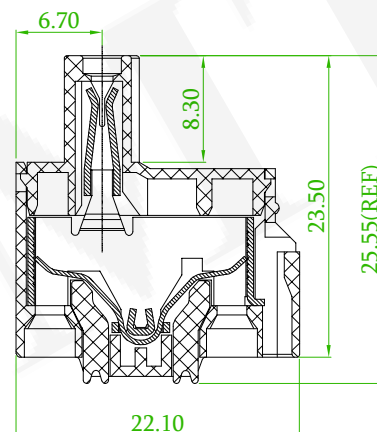
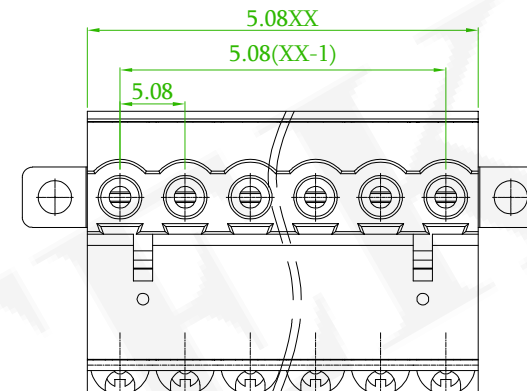
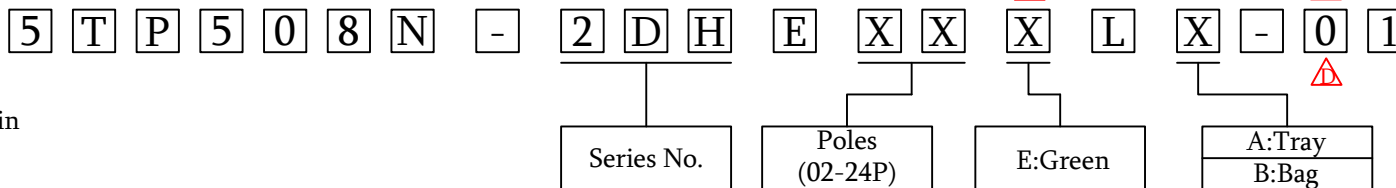

linear dimension (Tolerances Standard GB/T 14486-2008)



variable range	to 6	over 6 to 10	over 10 to 30	over 30 to 60	over 60 to 100	over 100 to 160	over 160 to 10	over 10 to 100	over 100 to	
tolerance	±0.20	±0.30	±0.50	±0.70	±1.00	±1.30	±1.60	0.10	0.30	0.60

REV.	ECN NO. OR DESCRIPTION	REVISED	DATE
△	ECN NO:230714 Revise the PART NO.	Gaby	2023/09/23
△x2	ECN NO:201215 Revise the PART NO.	Alice	2020/12/30
△x1	ECN NO:200718 Revise the Tolerance	Alice	2020/09/18

**糧德精密有限公司**  
 Amtek Technology Co., Ltd.  
 TEL: 886-2-2260-6878  
 FAX: 886-2-2260-8030

品名 TITLE	5.08mm Terminal Block				頁數 Page	1/1
品號 PART NO.	△ 5TP508N-2DHEXXXLX-01 △		繪圖 DRAWN	Eric		2018/12/04
圖號 DRAWING NO.	GN011-EA172	版本 REV.	D	核對 CHECKED	Josh	
客戶品號 CUSTOMER P/N		比例 SCALE	None	承認 APPROVED	Jason	
公差 TOLERANCE		單位 UNIT	mm	THIRD ANGLE PROJECTION		