

**ELECTRICAL**

Standard: UL IEC  
 Rated Voltage: 125V 130V  
 Rated Current: 8A 7A  
 Wire Range: 28-16AWG 1.5mm<sup>2</sup>  
 Dielectric Voltage: AC 2000V for one minute

**ORDER INFORMATION**

5 T P 3 5 0 N - 5 K 3 E X X E L B - 0 1

350:  
Pitch 3.50mm

Series No.

No of Pins total  
(02~24P)

E:Green

L:RoHS + Nylon 66  
Soldering Temperature:  
200 / 230°C / 5~10 Sec



**MECHANICAL**

Torque: 2Kgf. cm  
 Strip Length: 6~7mm  
 Temp. Range: -40°C ~ +105°C



**MATERIAL**

Housing: Nylon 66, UL94V-0  
 Screws: M2.5, Steel, Zn Plated  
 Pin Header: Brass, Tin Plated  
 Wire Guard: Brass, Ni Plated

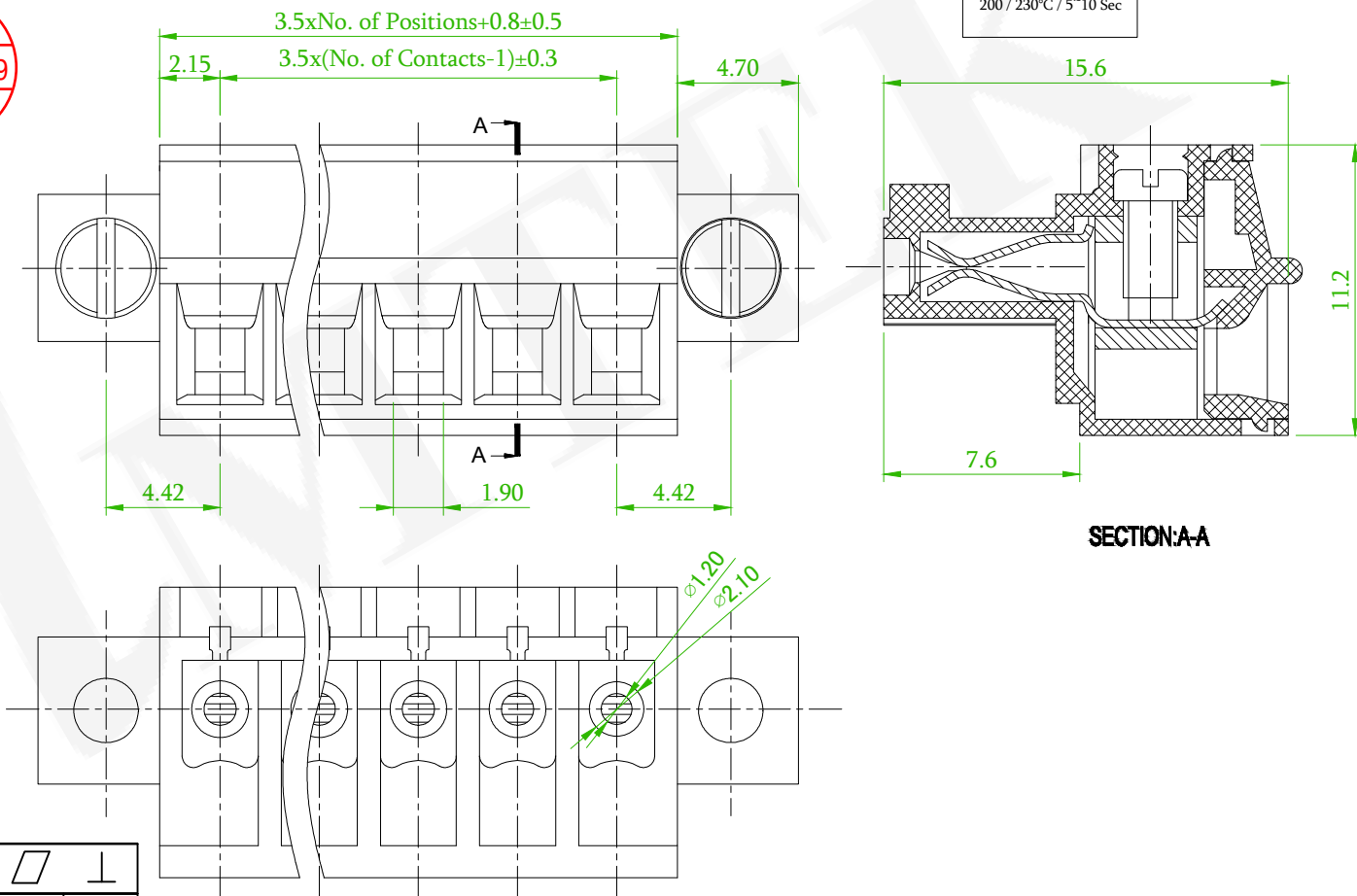

SECTION:A-A



linear dimension (Tolerances Standard GB/T 14486-2008)



variable range	to 6	over 6 to 10	over 10 to 30	over 30 to 60	over 60 to 100	over 100 to 160	over 160 to 10	over 10 to 100	over 100 to 100	
tolerance	±0.20	±0.30	±0.50	±0.70	±1.00	±1.30	±1.60	0.10	0.30	0.60

Old Part No. :TB15EKM-3.5-XXP-1X-00A-L

**糧德精密有限公司**  
 Amtek Technology Co., Ltd.  
 TEL: 886-2-2260-6878  
 FAX: 886-2-2260-8030

品名 TITLE	Terminal Block				頁數 Page	1/1
品號 PART NO.	5TP350N-5K3EXXELB-01			繪圖 DRAWN	Joe 2010/01/28	
圖號 DRAWING NO.	GN011-GA577		版本 REV.	B	核對 CHECKED	Paul 2010/01/28
客戶品號 CUSTOMER P/N			比例 SCALE	None	承認 APPROVED	James 2010/01/28
公差 TOLERANCE	.X ±0.20	.XX ±0.10	單位 UNIT	mm	THIRD ANGLE PROJECTION	

REV.	ECN NO. OR DESCRIPTION	REVISED	DATE
	ECN NO:200718 Revise the Dimension	Alice	2020/09/04