

**ELECTRICAL**

Standard: UL IEC  
 Rated Voltage: 300V 250V  
 Rated Current: 15A 16A  
 Contact Resistance: 20mΩ  
 Insulation Resistance: 500MΩ / DC 500V  
 Wire Rang: 28~12AWG 2.5mm<sup>2</sup>  
 Withstanding Voltage: AC 2000V for one minute

**MECHANICAL**

Steip Length: 8-9mm  
 Temp. Range: -40°C~+105°C

**Dimensions**

Pitch: 7.62mm  
 Poles: 2-24P

**MATERIAL**

Housing: PA66, UL94V-0  
 Wire guard: Stainless Steel  
 Pin header: Red Copper , Tin plated

**ORDER INFORMATION**

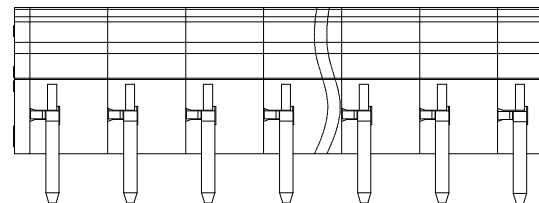
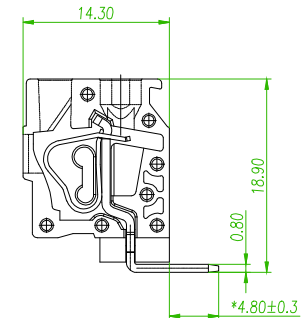
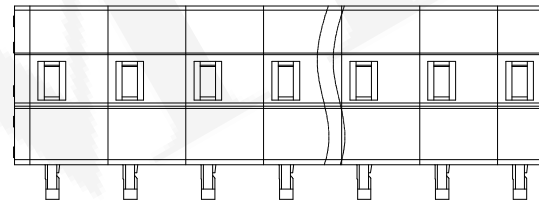
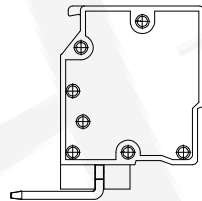
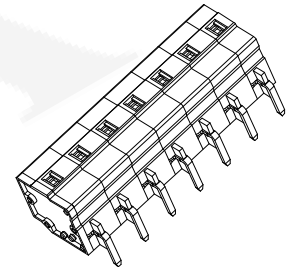
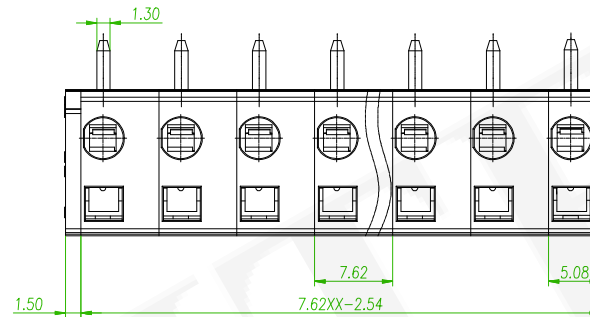
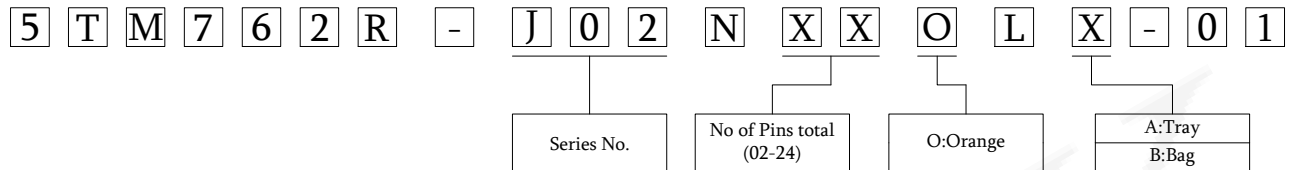

**B**

linear dimension (Tolerances Standard GB/T 14486-2008)								—	□	⊥
variable range	to 6	over 6 to 10	over 10 to 30	over 30 to 60	over 60 to 100	over 100 to 160	to 10	over 10 to 100	over 100 to 100	
tolerance	±0.20	±0.30	±0.50	±0.70	±1.00	±1.30	±1.60	0.10	0.30	0.60

<b>B</b> x1	ECN NO:200718 Revise the Tolerance	Alice	2020/11/05
REV.	ECN NO. OR DESCRIPTION	REVISED	DATE

**糧德精密有限公司**  
 Amtek Technology Co., Ltd.  
 TEL: 886-2-2260-6878  
 FAX: 886-2-2260-8030

品名 TITLE	Terminal Block				頁數 Page	1/1
品號 PART NO.	5TM762R-J02NXXOLX-01			繪圖 DRAWN	Benson 2020/02/03	
圖號 DRAWING NO.	GN011-BS801	版本 REV.	B	核對 CHECKED	Josh 2020/02/03	
客戶品號 CUSTOMER P/N		比例 SCALE	None	承認 APPROVED	Josh 2020/02/03	
公差 TOLERANCE		單位 UNIT	mm	THIRD ANGLE PROJECTION		