

**Electrical** B  
 Standard: UL  
 Rated Voltage: 300V  
 Rated Current: 20A  
 Contact Resistance: 20mΩ  
 Insulation Resistance: 500MΩ / DC 500V  
 Wire Range: 22-12AWG 2.5mm<sup>2</sup>  
 Dielectric Voltage: AC 2000V for one minute

**Mechanical**  
 Temp. Range: -40°C ~ +105°C  
 Torque: 1.2Nm

**Material**  
 Housing: Nylon 66, UL94V-0  
 Screws: M4.0, Steel, Ni Plated  
 Pin Header: Copper Alloy, Tin Plated  
 Cover: PC, UL94V-2

# ORDER INFORMATION

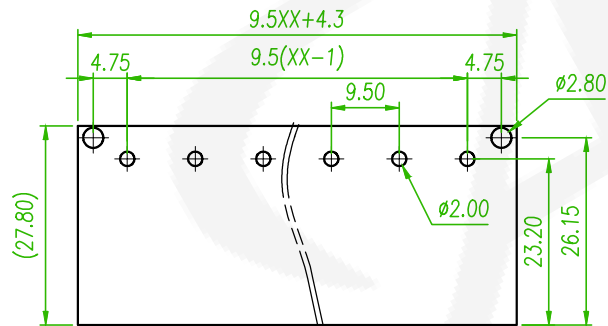
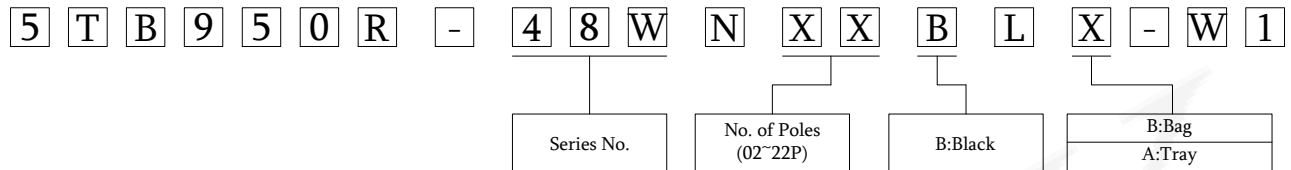

Recommended PCB Layout

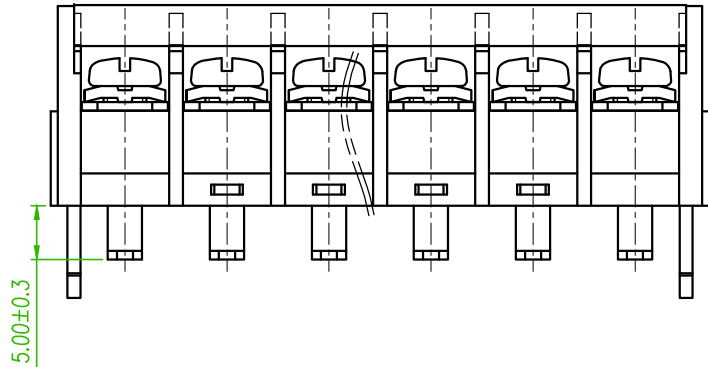
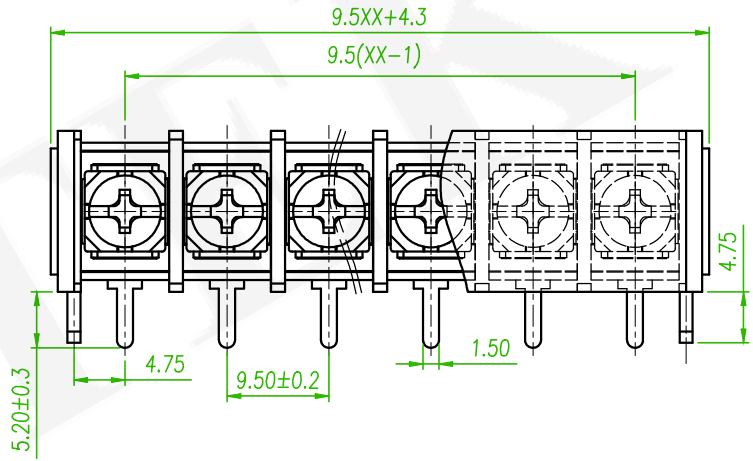
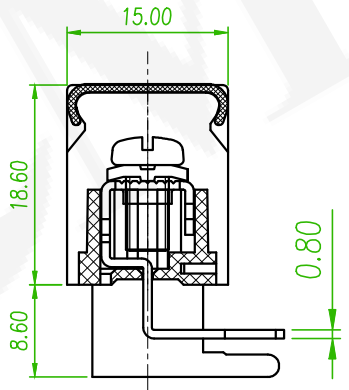

linear dimension (Tolerances Standard GB/T 14486-2008)										
variable range	to 6	over 6 to 10	over 10 to 30	over 30 to 60	over 60 to 100	over 100 to 160	over 160 to 10	over 10 to 100	over 100 to	
tolerance	±0.20	±0.30	±0.50	±0.70	±1.00	±1.30	±1.60	0.10	0.30	0.60

<span style="border: 1px solid black; padding: 2px;">Cx3</span>	ECN NO:200718 Revise the Tolerance & ECN NO:201211 Revise the PART NO.	Alice	2020/12/23
<span style="border: 1px solid black; padding: 2px;">Bx1</span>	ECN 200102: Remove the IEC	David	2020/06/06
REV.	ECN NO. OR DESCRIPTION	REVISED	DATE

糧德精密有限公司  
 Amtek Technology Co., Ltd.  
 TEL: 886-2-2260-6878  
 FAX: 886-2-2260-8030

品名 TITLE	9.5mm Terminal Block				頁數 Page	1/1
品號 PART NO.	<span style="border: 1px solid black; padding: 2px;">C</span> 5TB950R-48WNXXBLX-W1			繪圖 DRAWN	Roy 2019/01/02	
圖號 DRAWING NO.	GN011-R1094	版本 REV.	C	核對 CHECKED	Josh 2019/01/02	
客戶品號 CUSTOMER P/N		比例 SCALE	None	承認 APPROVED	Jason 2019/01/02	
公差 TOLERANCE		單位 UNIT	mm	THIRD ANGLE PROJECTION		