

CAVITY CONFIRMS TO FCC RULES AND REGULATIONS PART 68, SUBPART F.

ORDER INFORMATION

- MATERIAL:
 - HOUSING: PBT OR PA46, WITH GLASS FIBER, UL94V-0, STANDARD COLOR-BLACK.
 - INSERT HOUSING: PBT OR PA46, WITH GLASS FIBER, UL94V-0, STANDARD COLOR-BLACK.
 - CONTACTS: PHOSPHOR BRONZE.
 - SHELL: BRASS.
 - LED SOLDER TAIL: STEEL.
- FINISH:
 - CONTACTS: GOLD PLATED ON CONTACT AREA, GOLD FLASH ON SOLDER TAIL, 1.27μm [50μ"] MIN. NICKEL UNDERPLATED OVERALL.
 - SHELL: 0.508μm [20μ"] MIN. NICKEL PLATED.
 - LED SOLDER TAIL: 2.032μm [80μ"] MIN. TIN PLATED.

5 R J 1 D R X 0 R 2 N - 8 8 X X P X X - 742 - B 3



Panel Ground
 1: Non Panel Ground
 2: Top & Side Panel Ground
 3: Top Panel Ground
 5: Top & Side & Bottom Panel Ground
 6: Top & Bottom Panel Ground

N:W/O Ear	Number of position 8:8P	Number of contact 8:8C	Gold Plating GA:6u" GF:15u" GD:30u" GH:50u"	LED Position P:Parallel Pin	See LED Color Options Table
-----------	----------------------------	---------------------------	---	--------------------------------	-----------------------------

U:RoHS + PA46+Tray
L:RoHS + P.B.T+Tray



Left(LED1)	Right(LED2)	No.
Yellow	Green	1
Yellow	Yellow	2
Green	Yellow	3
Green	Green	4

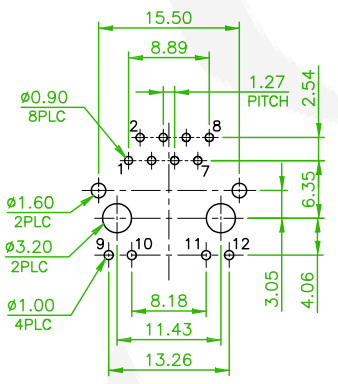
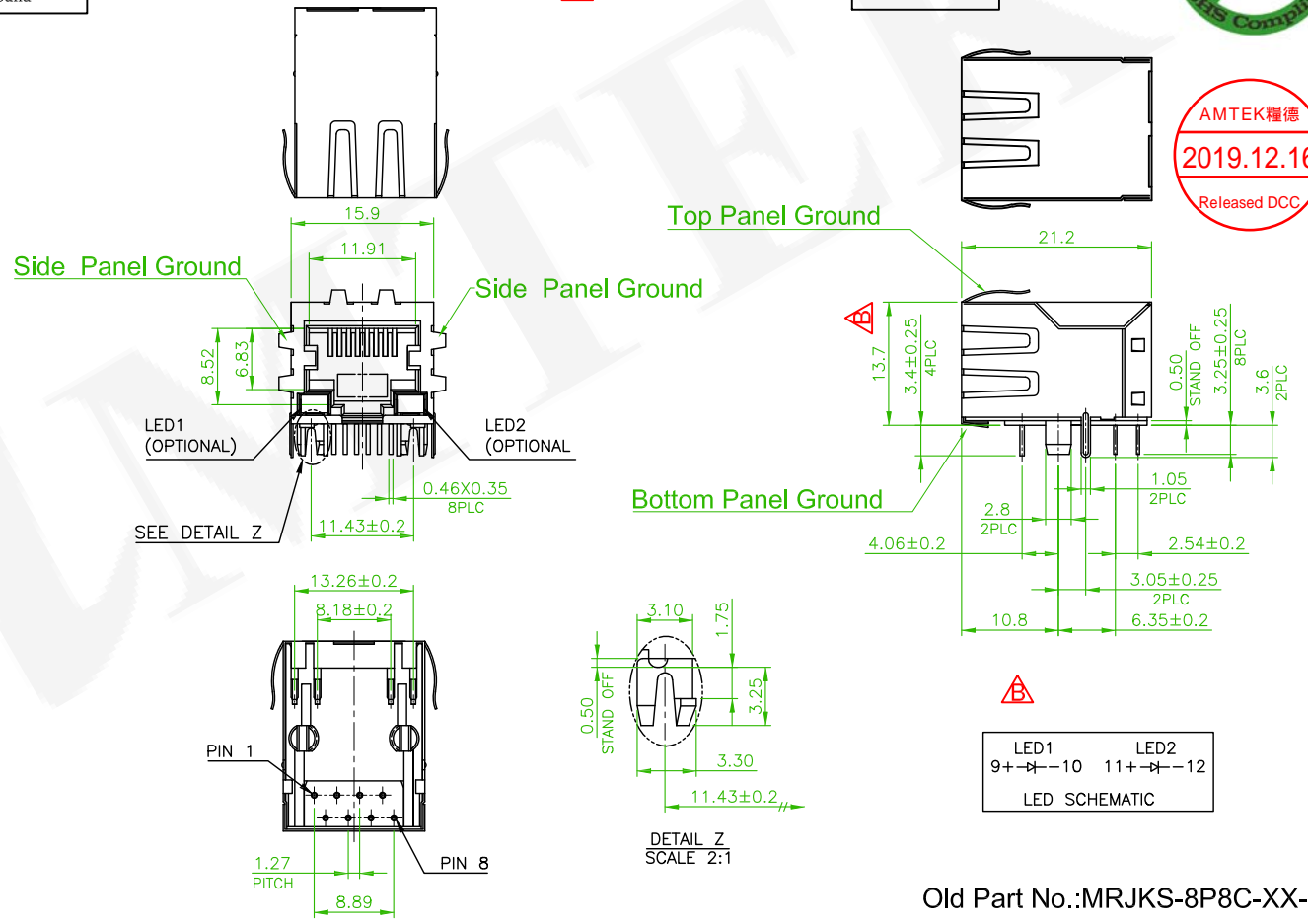

Old Part No.:MRJKS-8P8C-XX-L

REV.	ECN NO. OR DESCRIPTION	REVISED	DATE
X1	ECN 191104;Revise the Narrative	Nick	2019/11/26
X1	ECN NO.:180605,Revise the Plated:G5->GH	Mia	2018/10/08
X1	Revised the Part No.:5RJ1DRX0R2N-88XXPXX-742-B1->5RJ1DRX0R2N-88XXPXX-742-B3	Jeff	2017/03/29
X4	1.Revised the drawing 2. Part No.:5RJ1DR20R2N-88XXXXL-742-B1->5RJ1DRX0R2N-88XXPXL-742-B1	Mia	2016/12/22

 糧德精密有限公司 Amtek Technology Co., Ltd. TEL: 886-2-2260-6878 FAX: 886-2-2260-8030	品名 TITLE	MODULAR JACK SHIELDED SIDE ENTRY WITH LED H=13.6 W=21.2			頁數 Page	1/1
	品號 PART NO.	5RJ1DRX0R2N-88XXPXX-742-B3			繪圖 DRAWN	Jeff 2015/09/16
	圖號 DRAWING NO.	GW082-MC163	版本 REV.	E	核對 CHECKED	John 2015/09/16
	客戶品號 CUSTOMER P/N		比例 SCALE	None	承認 APPROVED	John 2015/09/16
	公差 TOLERANCE	.X ±0.25 .XX ±0.13	單位 UNIT	mm	THIRD ANGLE PROJECTION	