

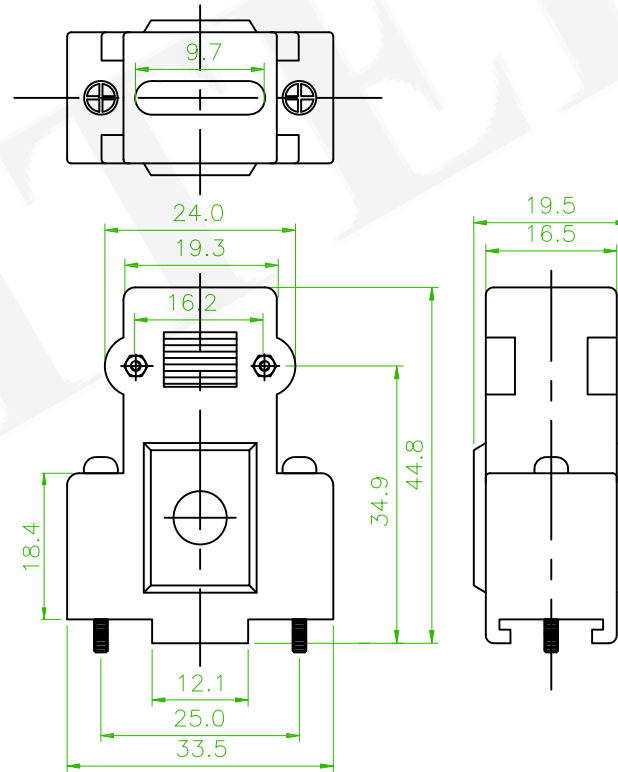

MATERIAL: 
 INSULATOR : ABS UL94HB
 SCREW: STEEL
 FINISHED : CHROMATE PLATED

ORDER INFORMATION

5 H D 1 1 5 A I - 0 9 X X A 1

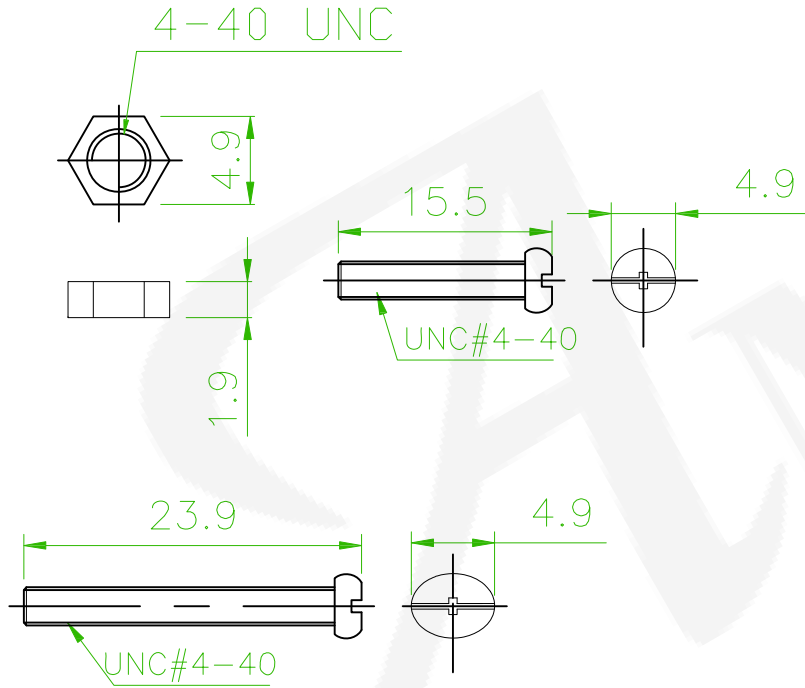
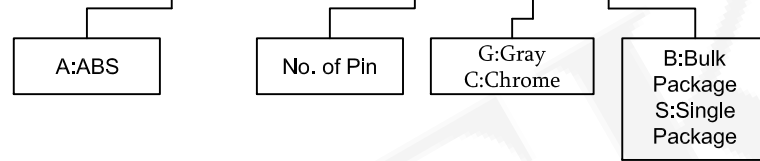

 x1	ECN-191112 Add the SPEC	Nick	2019/12/05
REV.	ECN NO. OR DESCRIPTION	REVISED	DATE

 糧德精密有限公司 Amtek Technology Co., Ltd. TEL: 886-2-2260-6878 FAX: 886-2-2260-8030	品名 TITLE	Hood 115 09P				頁數 Page	1/1
	品號 PART NO.	5HD115AI-09XXA1			繪圖 DRAWN	Eric 2019/01/24	
	圖號 DRAWING NO.	GW001-EA622	版本 REV.	B	核對 CHECKED	Josh 2019/01/24	
	客戶品號 CUSTOMER P/N		比例 SCALE	None	承認 APPROVED	Josh 2019/01/24	
	公差 TOLERANCE	.X ± 0.30 .XX ± 0.20	單位 UNIT	mm	THIRD ANGLE PROJECTION	