

MATERIAL:

1.BRASS

ORDER INFORMATION

5 G B S - 0 1 8 X X - A 1

◎:Standard Recommend

T0:Tin Plated
◎TM:Matte Tin

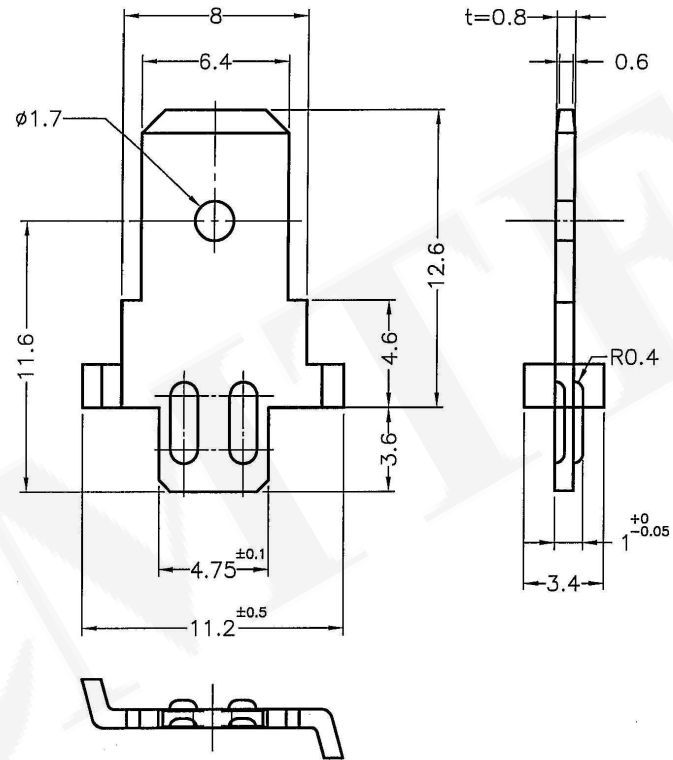
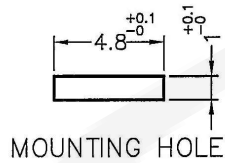

RoHS Compliant	
★Pb	<1000PPM
★Cd	< 100PPM
★Hg	<1000PPM
★Cr6+	<1000PPM
★PBBs	<1000PPM
★PBDEs	<1000PPM

耀德精密有限公司
Amtek Technology Co., Ltd.
TEL: 886-2-2260-6878
FAX: 886-2-2260-8030

品名 TITLE	P.C.B Terminal				頁數 Page	1/1
品號 PART NO.	5GBS-018XX-A1			繪圖 DRAWN	David 2020/01/06	
圖號 DRAWING NO.	GW018-DV623	版本 REV.	B	核對 CHECKED	Josh 2020/01/06	
客戶品號 CUSTOMER P/N		比例 SCALE	None	承認 APPROVED	Josh 2020/01/06	
公差 TOLERANCE	±0.25	單位 UNIT	mm	THIRD ANGLE PROJECTION		

△	QEC NO.:231104 Revise the Plating Options	Gaby	2023/12/11
REV.	ECN NO. OR DESCRIPTION	REVISED	DATE