

# MATERIAL

Contact Pin: Brass

# ORDER INFORMATION

5 G B M - 0 3 0 X X - A 1

◎:Standard Recommend

T0: Tin Plated  
 ◎TM: Matte Tin

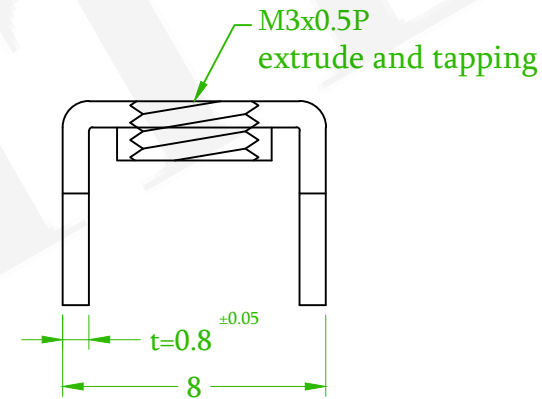
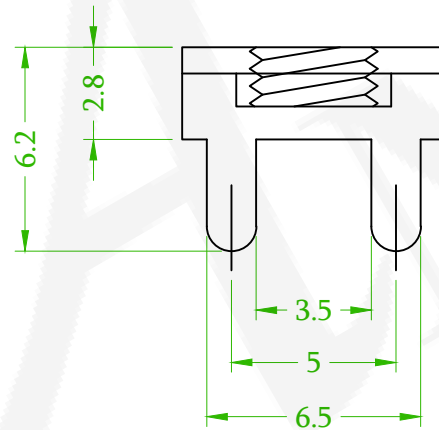
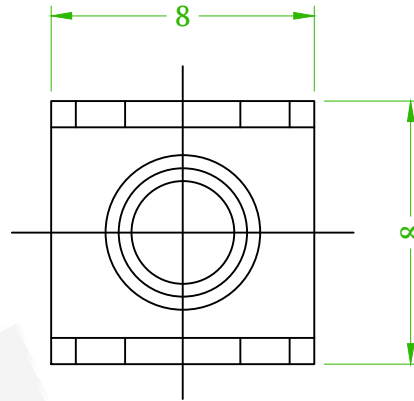

(RoHS Compliant)	
Pb	<1000PPM
Cd	< 100PPM
Hg	<1000PPM
Cr6+	<1000PPM
PBBs	<1000PPM
PBDEs	<1000PPM

NOTE: 1. THE BEST USE TIME OF TIN PLATING PARTS ARE WITHIN 3 MONTHS SINCE MFG DATE.  
 2. FINISH: TIN PLATED. IF PARTS ARE NOT USED UP PLEASE STORE IN A SEAL BAG.

 糧德精密有限公司 Amtek Technology Co., Ltd. TEL: 886-2-2260-6878 FAX: 886-2-2260-8030	品名 TITLE	P.C.B Terminal			頁數 Page	1/1
	品號 PART NO.	5GBM-030XX-A1			繪圖 DRAWN	Benson 2019/12/30
	圖號 DRAWING NO.	GW018-BS618	版本 REV.	B	核對 CHECKED	Josh 2019/12/30
	客戶品號 CUSTOMER P/N		比例 SCALE	None	承認 APPROVED	Josh 2019/12/30
	公差 TOLERANCE	±0.2	單位 UNIT	mm	THIRD ANGLE PROJECTION	

REV.	QEC NO.:231104 Revise the Plating Options	Gaby	2023/11/27
	ECN NO. OR DESCRIPTION	REVISED	DATE