

MATERIAL

Contact Pin: Brass

NOTE

1. THE BEST USE TIME OF TIN PLATING PARTS ARE WITHIN 3 MONTHS SINCE MFG DATE.
2. TIN PLATED. IF PARTS ARE NOT USED UP PLEASE STORE IN A SEAL BAG.
3. LOAD CURRENT: 15A.

ORDER INFORMATION

5 G B M - 0 1 2 X X - A X

◎: Standard Recommend

T0: Tin Plated
◎ TM: Matte Tin

See Table

AMTEK 禮德
2023.12.20
Released DCC

PART NO.	TAPPED
5GBM-012XX-A1	M3X0.5P
5GBM-012XX-A2	M4X0.7P

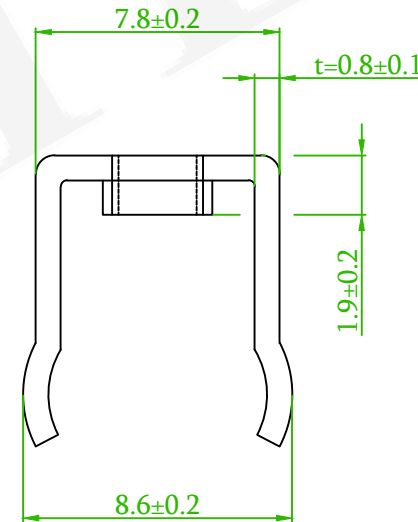
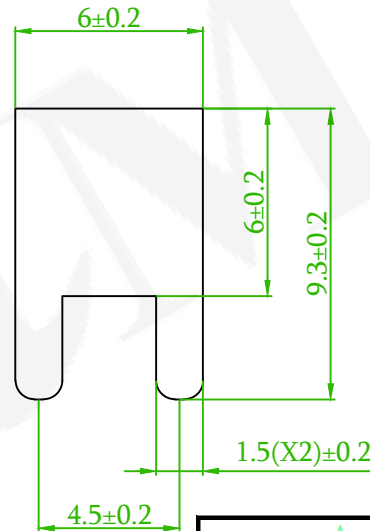
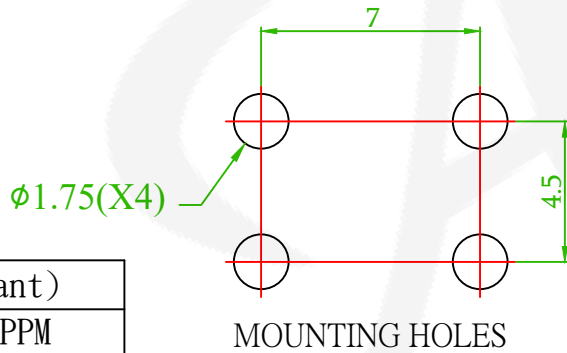
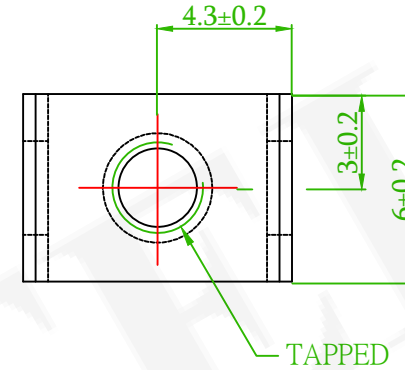

(RoHS Compliant)

★ Pb	<1000PPM
★ Cd	< 100PPM
★ Hg	<1000PPM
★ Cr6+	<1000PPM
★ PBBs	<1000PPM
★ PBDEs	<1000PPM

QEC NO.: 231104 Revise the Plating Options

Gaby 2023/11/27

禮德精密有限公司
Amtek Technology Co., Ltd.
TEL: 886-2-2260-6878
FAX: 886-2-2260-8030

品名 TITLE	P.C.B TERMINAL				頁數 Page	1/1
品號 PART NO.	5GBM-012XX-AX			繪圖 DRAWN	Nick 2019/12/31	
圖號 DRAWING NO.	GW018-NI704	版本 REV.	B	核對 CHECKED	Josh 2019/12/31	
客戶品號 CUSTOMER P/N		比例 SCALE	None	承認 APPROVED	Josh 2019/12/31	
公差 TOLERANCE		單位 UNIT	mm	THIRD ANGLE PROJECTION		

REV. ECN NO. OR DESCRIPTION

REVISED DATE