

SPECIFICATIONS

Current Rating: 2.0A AC, DC
 Contact Resistance: 30mΩ Max.
 Insulation Resistance: 1000MΩ Min.
 Dielectric Voltage: 1000V AC for one minute
 Operation Temperature: -40°C to +105°C

MATERIAL

Insulator: PBT, UL94V-0
 Contact Pin: Brass

ORDER INFORMATION

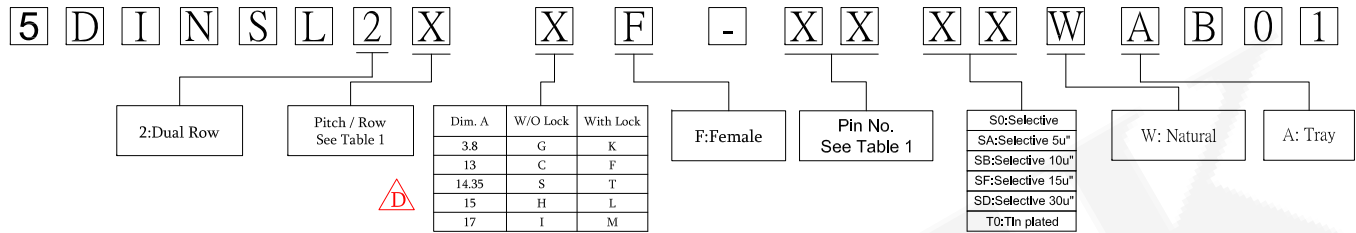
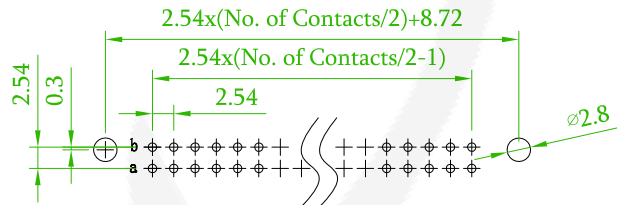
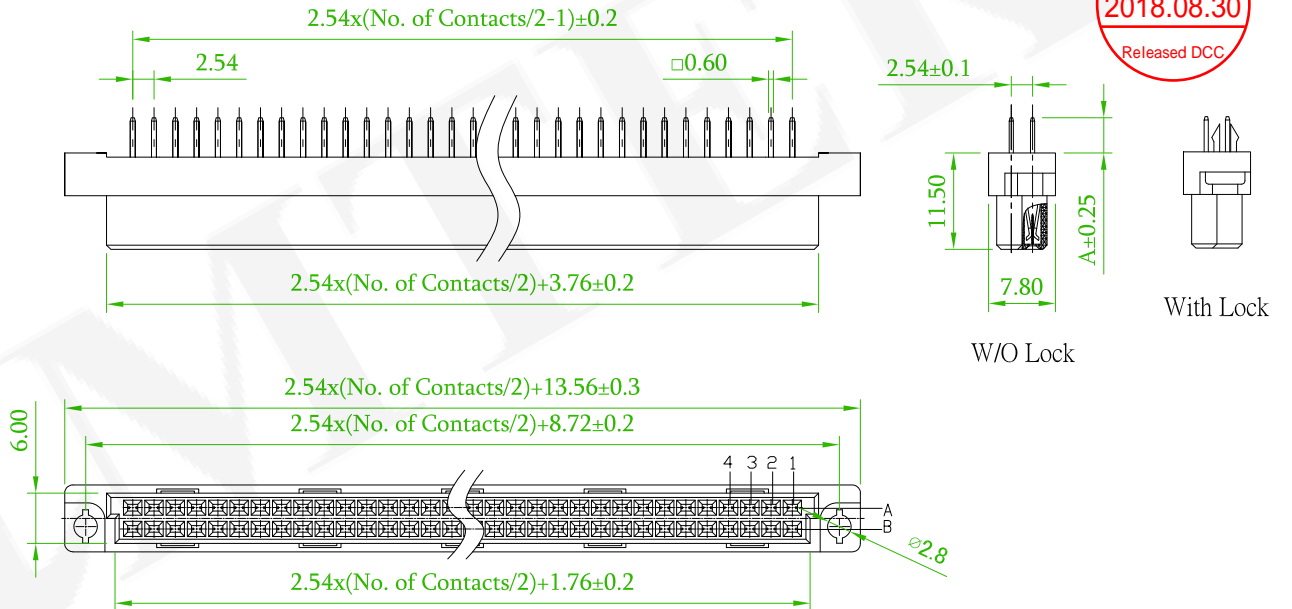

Table 1

Part No.	Pin No.	Pitch	Rows with Pins	Contact Arrange
5DINSL2BXF-64 ***	64	2.54	A B	
5DINSL2DXF-32 ***	32		A -	
5DINSL2FXF-32 ***	32	5.08	A B	
5DINSL2HXF-16 ***	16		A -	



Recommended PCB Layout
 (PCB TOLERANCE ±0.05)

Old Part No.:DINLS-F2XX-L

△D x1	Add options: C, F, S, T, H, L, I, M.	Gary	2018/08/30
△C x1	Revise the Table 1	Roy	2018/05/08
△B	Revise the Drawing	Jeff	2016/06/17
REV.	ECN NO. OR DESCRIPTION	REVISED	DATE

 耀德精密有限公司 Amtek Technology Co., Ltd. TEL: 886-2-2260-6878 FAX: 886-2-2260-8030	品名 TITLE	DIN 41612 D/R V/T DIP TYPE			頁數 Page	1/1
	品號 PART NO.	5DINSL2XXF-XXXXWAB01			繪圖 DRAWN	Roy 2016/04/07
	圖號 DRAWING NO.	GN087-RR462	版本 REV.	D	核對 CHECKED	Josh 2018/08/30
	客戶品號 CUSTOMER P/N		比例 SCALE	None	承認 APPROVED	Jason 2018/08/30
	公差 TOLERANCE	.X ±0.30 .XX ±0.20	單位 UNIT	mm	THIRD ANGLE PROJECTION	