

SPECIFICATION

Current Rate:3 AMP
 Insulation Resistance:1000M Ω Min.
 Contact Resistance:30m Ω Max.
 Dielectric Voltage:1000V AC for one minute
 Operation Temperature:-40°C to +105°C
 Max.Processing Temp:180°C for 30-60 seconds(200°C for 10 seconds)

MATERIAL

Insulator:Polyester,UL 94V-0 ©Standard:P.B.T
 Contact Pin:Phosphor Bronze

ORDER INFORMATION

5 D I N I S 3 C N F - 3 2 S 0 W A B 0 1

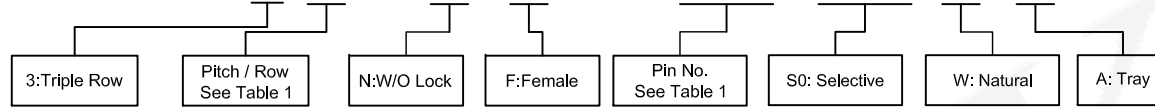

©:Standard Recommend

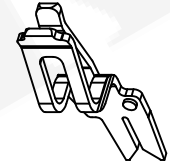
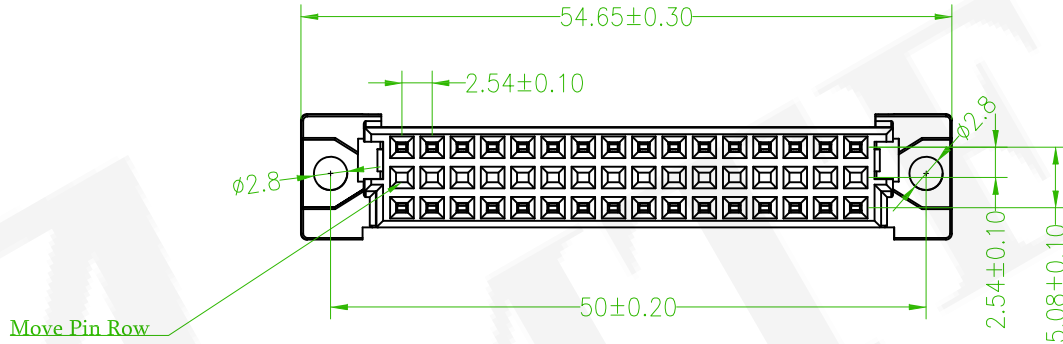
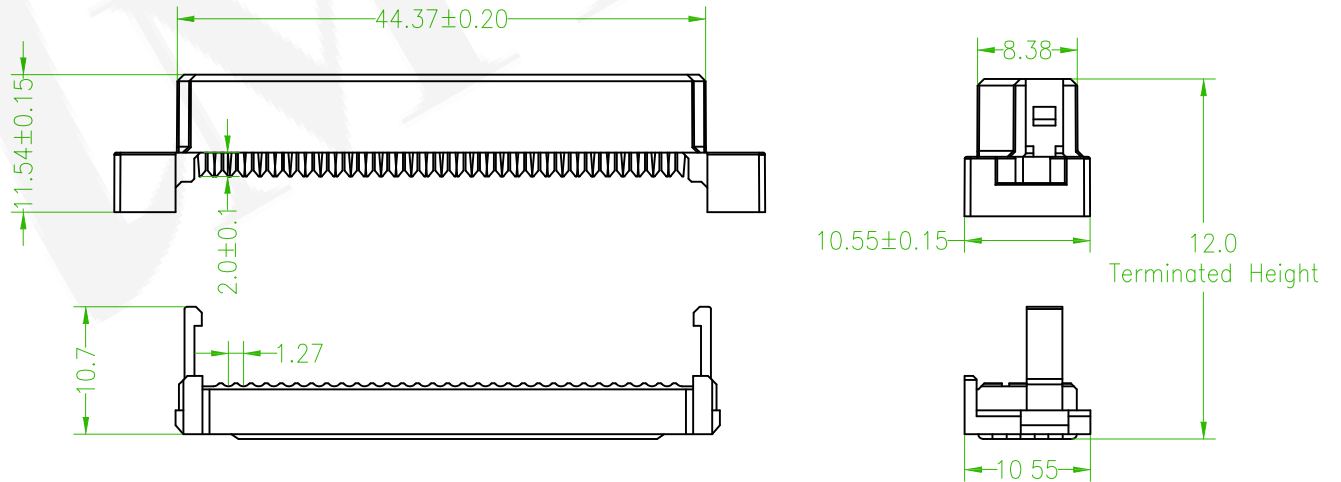

Table 1

Part No.	Pin No.	Pitch	Rows with Pins	Contact Arrange
5DINIS3CNF-32 ***	32	2.54	A - C	



Old Part No.:DINSI-F332SW-L

REV.	Revise the Table 1	Roy	2018/05/08
	ECN NO. OR DESCRIPTION	REVISED	DATE

糧德精密有限公司
 Amtek Technology Co., Ltd.
 TEL: 886-2-2260-6878
 FAX: 886-2-2260-8030

品名 TITLE	DIN 41612 3-R IDC TYPE				頁數 Page	1/1
品號 PART NO.	5DINIS3CNF-32S0WAB01			繪圖 DRAWN	Jeff 2015/09/16	
圖號 DRAWING NO.	GN087-RR455		版本 REV.	B	核對 CHECKED	Josh 2018/05/08
客戶品號 CUSTOMER P/N			比例 SCALE	None	承認 APPROVED	Jason 2018/05/08
公差 TOLERANCE	.X ±0.30 .XX ±0.20	單位 UNIT	mm	THIRD ANGLE PROJECTION		