

**SPECIFICATIONS**

Current Rating: 5 Amp  
 Insulator Resistance: 5000MΩ min.  
 Dielectric Withstanding Voltage: AC 1000V min.  
 Contact Resistance: 10mΩ max.  
 Operating Temperature: -55°C - +85°C

**MATERIAL**

Insulator: PBT, UL94V-0  
 Terminal: Copper Alloy

**ORDER INFORMATION**

5 7 W H D S X M - X X N X X X B A - 0 1

1: Tin shell + L(RoHS)  
 2: Nickel shell + L(RoHS)

M: Male

No. of contacts  
(15,26,44)

N: Non

A: Revit  
 B: Revit + Screw Attached

G: Gold Flash  
 GD: Gold 30u"

Ⓢ: Black insulator

A: Tray

Ⓢ: Standard Recommend



AMTEK 耀德  
 2020.05.11  
 Released DCC

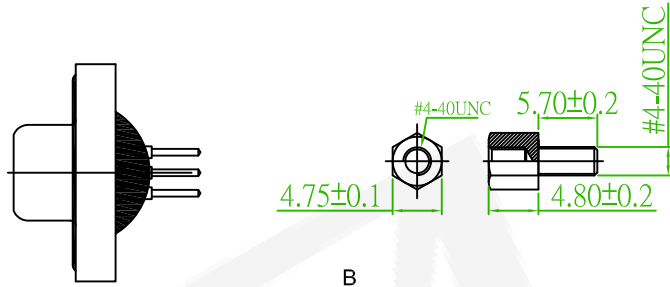

B

NO.	A ±0.25	B ±0.25	C ±0.13	D ±0.13	E ±0.25	F ±0.25	G ±0.25
15P	39.40	24.99	16.92	2.29	0.25	28.20	20.00
26P	47.70	33.32	25.25	2.29	0.51	36.50	28.00
44P	64.50	47.04	38.96	2.29	0.51	51.00	41.50

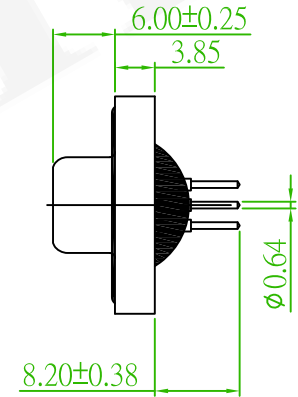
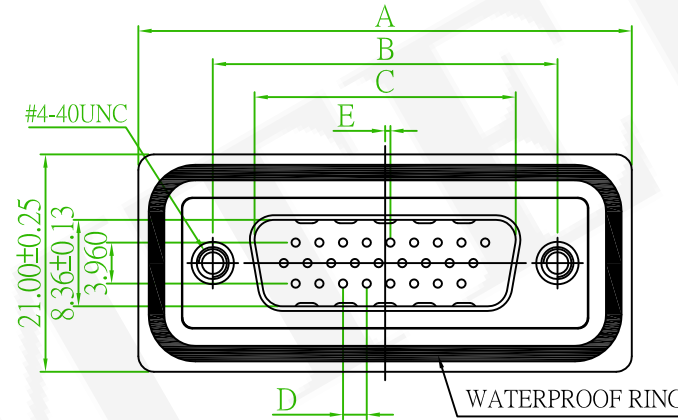

A

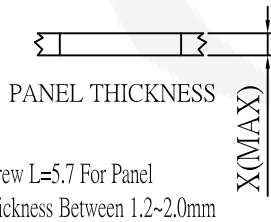

Screw L=5.7 For Panel Thickness Between 1.2~2.0mm

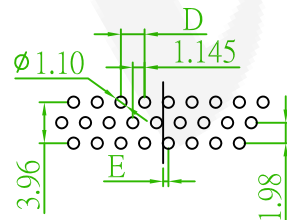

RECOMMENDED P.C.B LAYOUT

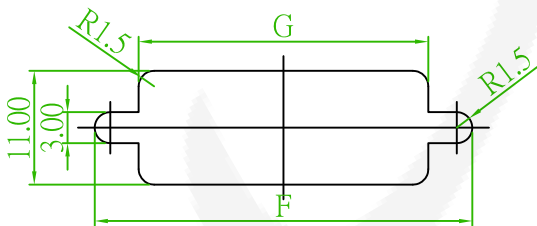

RECOMMENDED PANEL CUT-OUT

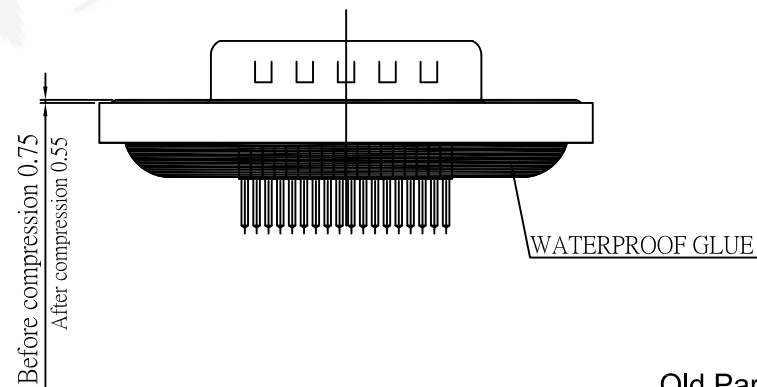

Old Part No.: WHDBD-MXX-L

REV.	ECN NO. OR DESCRIPTION	REVISED	DATE

品名 TITLE		WATERPROOF D-SUB DIP TYPE			
品號 PART NO.	57WHDSXM-XXNXXXBA-01	繪圖 DRAWN	Roy		2017/03/24
圖號 DRAWING NO.	GW037-RL613	版本 REV.	A	核對 CHECKED	Jonny
客戶品號 CUSTOMER P/N		比例 SCALE	None	承認 APPROVED	Aaron
公差 TOLERANCE	.X ± 0.38 .XX ± 0.25	X° ± 3°	單位 UNIT	mm	THIRD ANGLE PROJECTION

耀德精密有限公司  
 Amtek Technology Co., Ltd.  
 TEL: 886-2-2268-8036  
 FAX: 886-2-2268-8035