

Specifications

Current Rate: 3 AMP
 Insulation Resistance: 1000MΩ Min
 Contact Resistance: 30mΩ Max
 Dielectric voltage: 500V AC at sea level
 Operation Temperature: -55°C to +105°C

Material

Insulator: PBT, UL 94V-0
 Terminal: Copper Alloy
 Shell: SPCC
 Rivet: Copper Alloy

ORDER INFORMATION

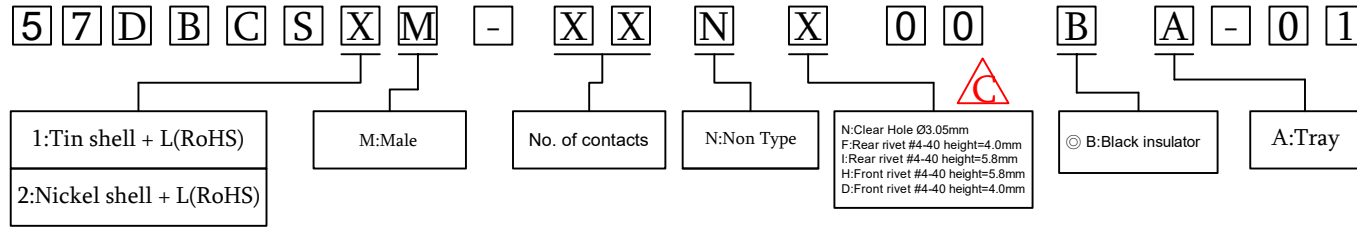

⊙: Standard Recommend

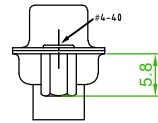
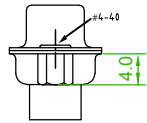

Rear rivet #4-40 height=4.0mm
57DBCSXM-XXNF00BA-01

Rear rivet #4-40 height=5.8mm
57DBCSXM-XXNI00BA-01

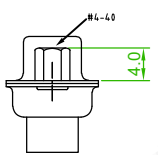
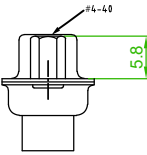

Front rivet #4-40 height=5.8mm
57DBCSXM-XXNH00BA-01

Front rivet #4-40 height=4.0mm
57DBCSXM-XXND00BA-01

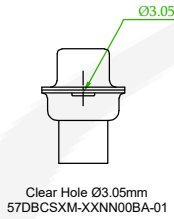

Clear Hole Ø3.05mm
57DBCSXM-XXN00BA-01

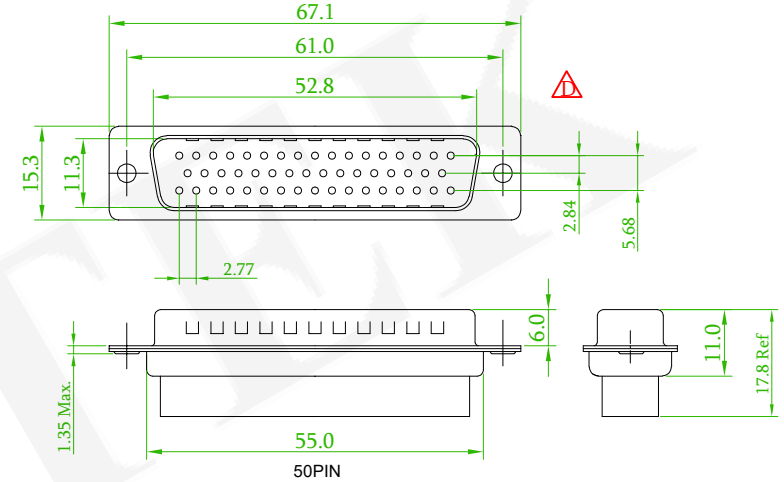
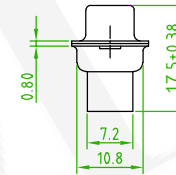
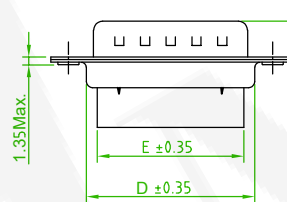
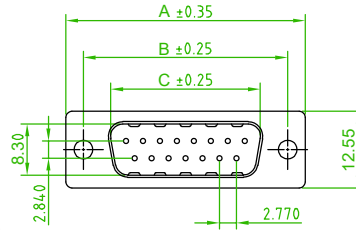

Note:

No.	A	B	C	D	E
09	30.81	24.99	16.95	19.15	15.60
15	39.14	33.32	25.30	27.51	24.40
25	53.04	47.04	39.00	41.00	37.90
37	69.32	63.50	55.40	57.30	54.40

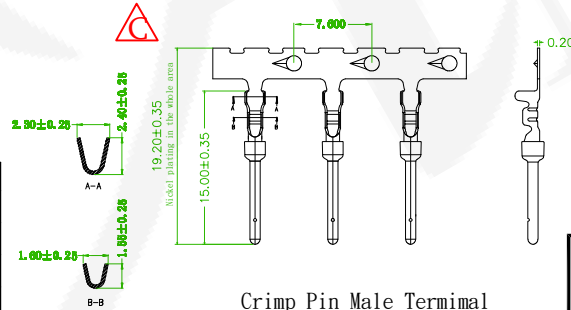

Crimp Pin Male Terminal
Part No.: 32BR-S00M0002

Old Part No.: DBC-MXX-L

品名 TITLE	D-SUB CRIMP TYPE				
	品號 PART NO.	57DBCSXM-XXNX00BA-01			繪圖 DRAWN
圖號 DRAWING NO.	GW054-AB549	版本 REV.	D	核對 CHECKED	John 2015/09/08
客戶品號 CUSTOMER P/N		比例 SCALE	None	承認 APPROVED	John 2015/09/08
公差 TOLERANCE	.X ±0.35 .XX ±0.25	.XXX ±0.15 ANGLES: ±2°	單位 UNIT	mm	THIRD ANGLE PROJECTION

糧德精密有限公司
Amtek Technology Co., Ltd.
TEL: 886-2-2268-8036
FAX: 886-2-2268-8035

△x1	Add 50PIN	Alice	2023/07/25
△x8	ECN NO.: 221220 Revise the Drawing	Rex	2023/01/18
△x1	ECN NO.: 220122 Revise the Drawing	Benson	2022/06/11
REV.	ECN NO. OR DESCRIPTION	REVISED	DATE