

NOTE

Material: BeCu

Thickness: 0.08mm

Electroplate:

Au >1u" on contact area

Au >1u" on solder area

Nickel underplating over all

Hight of Application:

1.20 ~ 2.20mm (Single actuation)

1.30 ~ 2.20mm (Repeated actuation)

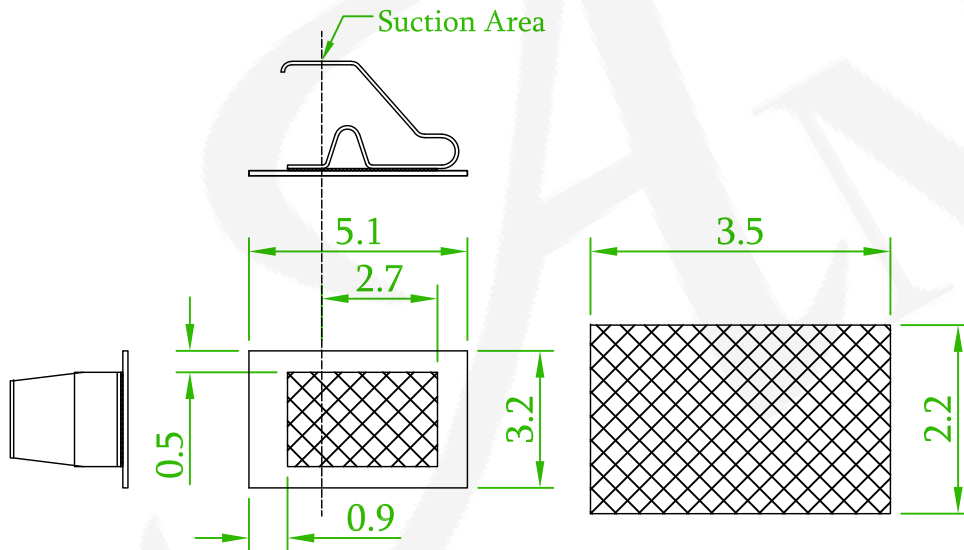
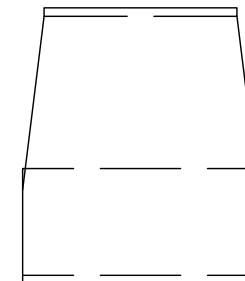
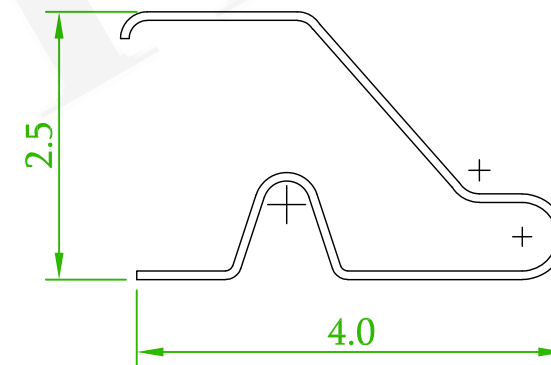
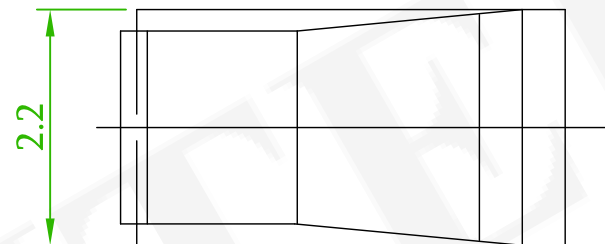

Recommended PCB Layout
(PCB TOLERANCE ±0.1)

REV.	ECN NO. OR DESCRIPTION	REVISED	DATE

 糧德精密有限公司 Amtek Technology Co., Ltd. TEL: 886-2-2260-6878 FAX: 886-2-2260-8030	品名 TITLE	EMI SPRING			頁數 Page	1/1
	品號 PART NO.	3SSL-NN25NN-NNNNG			繪圖 DRAWN	Nick 2019/08/05
	圖號 DRAWING NO.	GW271-NI292	版本 REV.	A	核對 CHECKED	Josh 2019/08/05
	客戶品號 CUSTOMER P/N		比例 SCALE	None	承認 APPROVED	Josh 2019/08/05
	公差 TOLERANCE	±0.20	單位 UNIT	mm	THIRD ANGLE PROJECTION	